

1-1-2013

Embodied Energy and Carbon Footprint of Household Latrines in Rural Peru: The Impact of Integrating Resource Recovery

Christopher M. Galvin

University of South Florida, cmgalvin@mail.usf.edu

Follow this and additional works at: <http://scholarcommons.usf.edu/etd>

 Part of the [Environmental Engineering Commons](#)

Scholar Commons Citation

Galvin, Christopher M., "Embodied Energy and Carbon Footprint of Household Latrines in Rural Peru: The Impact of Integrating Resource Recovery" (2013). *Graduate Theses and Dissertations*.

<http://scholarcommons.usf.edu/etd/4489>

This Thesis is brought to you for free and open access by the Graduate School at Scholar Commons. It has been accepted for inclusion in Graduate Theses and Dissertations by an authorized administrator of Scholar Commons. For more information, please contact scholarcommons@usf.edu.

Embodied Energy and Carbon Footprint of Household Latrines in Rural Peru:
The Impact of Integrating Resource Recovery

by

Christopher Galvin

A thesis submitted in partial fulfillment
of the requirements for the degree of
Master of Science in Environmental Engineering
Department of Civil and Environmental Engineering
College of Engineering
University of South Florida

Major Professor: James R. Mihelcic, Ph.D.
Qiong Zhang, Ph.D.
Daniel Yeh, Ph.D.

Date of Approval:
April 3, 2013

Keywords: Life Cycle Assessment, Sustainable Development, Sanitation, Anaerobic
Biodigestion, Global Warming

Copyright © 2013, Christopher Galvin

ACKNOWLEDGMENTS

I would like to take this opportunity to thank the following people and institutions that were instrumental in the completion of this project:

The University of South Florida and the United States Peace Corps, my advisor and committee members, Dr. James Mihelcic, Dr. Qiong Zhang, and Dr. Daniel Yeh, Pablo Cornejo, Christine Prouty, Michael MacCarthy, the wonderful people of Santo Domingo, Peru for allowing me to be part of their small community for two years, and my family for their support and understanding.

This material is based upon work supported by the National Science Foundation under Grant No. 0965743. Any opinions, findings, and conclusions or recommendations expressed in this material are those of the author(s) and do not necessarily reflect the views of the National Science Foundation.

TABLE OF CONTENTS

LIST OF TABLES.....	iii
LIST OF FIGURES	v
ABSTRACT.....	vi
CHAPTER 1: INTRODUCTION.....	1
1.1 Research Motivation.....	1
1.2 Objective and Hypotheses.....	4
CHAPTER 2: PREVIOUS RESEARCH AND BACKGROUND INFORMATION.....	6
2.1 Nutrient Content of Human Excreta.....	6
2.2 Anaerobic Digestion	7
2.3 Pathogen Destruction in Composting Latrines.....	9
2.4 Life Cycle Assessments Related to Water and Wastewater.....	12
2.5 Sanitation Technologies Evaluated in this Study.....	15
2.5.1 Ventilated Improved Pit Latrine	15
2.5.2 Composting Latrine.....	16
2.5.3 Pour-Flush Latrine.....	17
2.5.4 Biodigester Latrine	18
CHAPTER 3: METHODS	21
3.1 Goal and Scope Definition	21
3.2 Site Location.....	21
3.3 Defining the Functional Unit and System Boundary	23
3.3.1 Data Collection and Life Cycle Inventory.....	24
3.4 Calculations for Life Cycle Inventory.....	24
3.4.1 Material Production	24
3.4.2 Material Delivery	26
3.4.3 Biochemical Oxygen Demand Input	28
3.4.4 Anaerobic Degradation of Domestic Wastewater	29
3.4.5 Aerobic Degradation of Domestic Wastewater	30
3.4.6 Biogenic Emissions.....	30
3.4.7 Resource Recovery through Biogas and Nutrients.....	32
3.4.7.1 Biogas	32
3.4.7.2 Biodigester Effluent.....	33
3.4.7.3 Compost and Urine Diversion	34
3.5 Sensitivity Analysis	34
3.6 Life Cycle Impact Assessment and Interpretation	35
CHAPTER 4: RESULTS AND DISCUSSION	36
4.1 Impact of Privacy Structure on CED and GWP	36
4.2 CED and GWP Associated with Use Phase and Resource Recovery.....	41
4.3 CED and GWP of Household and Community-Level Sanitation Systems	47

4.4 Sensitivity Analysis	50
CHAPTER 5: CONCLUSIONS AND RECOMMENDATIONS FOR FUTURE RESEARCH.....	54
REFERENCES	57
APPENDICES.....	63
Appendix A Material Inventories	64
Appendix B LCA Results Data.....	78
Appendix C Permissions	87
C.1 Cairncross and Feachem (1993) Permission.....	87
C.2 Buckley et al. (2008) Permission	87
C.3 Mihelcic et al. (2009) Permission.....	87

LIST OF TABLES

Table 1: Burden of diarrheal disease by global region, 2000	2
Table 2: Characteristics of daily human excreta per person	6
Table 3: Nutrient concentrations of potential biodigester feeds	8
Table 4: Microbiological analysis of five samples obtained from active compost latrines in Panama	12
Table 5: Chemical composition of compost samples	12
Table 6: Embodied energy of eight water supply interventions in Mali.....	15
Table 7: Basic characteristics of the four latrine technologies considered in this study.....	23
Table 8: Model input data collected and SimaPro inputs	28
Table 9: Distances to site location from material origins.....	29
Table 10: Biogenic emissions associated with each system.....	32
Table 11: Latrine design variations considered in this study.....	37
Table 12: Cumulative energy demand of latrine components for construction phase	39
Table 13: Global warming potential of latrine components for construction phase.....	40
Table 14: Contributions to cumulative energy demand of four sanitation systems that consider resource recovery over 20-year life.....	42
Table 15: Contributions to global warming potential of sanitation systems over 20-year life	45
Table 16: Sensitivity factors for privacy shelter (construction phase) results	52
Table 17: Sensitivity factors for construction and use phase results.....	53
Table A.1: Material inventory for VIP latrine adobe fiber cement privacy structure	64
Table A.2: Material inventory for VIP latrine brick corrugated metal privacy structure.....	65
Table A.3: Material inventory for VIP latrine adobe fiber cement privacy structure (unlined pit).....	66

Table A.4: Material inventory for pour-flush latrine adobe fiber cement privacy structure	67
Table A.5: Material inventory for pour-flush latrine brick corrugated metal privacy structure.....	68
Table A.6: Material inventory for composting latrine adobe fiber cement privacy structure.....	70
Table A.7: Material inventory for composting latrine brick corrugated metal privacy structure ...	71
Table A.8: Material inventory for biodigester latrine adobe fiber cement privacy structure.....	73
Table A.9: Material inventory for biodigester latrine brick corrugated metal privacy structure	75
Table B.1: LCA results for construction and use phase of VIP latrine adobe fiber cement privacy structure	78
Table B.2: LCA results for construction phase of VIP latrine brick corrugated metal privacy structure	79
Table B.3: LCA results for construction phase of VIP latrine adobe fiber cement (unlined pit) privacy structure	80
Table B.4: LCA results for construction and use phase of pour-flush latrine adobe fiber cement privacy structure.....	81
Table B.5: LCA results for construction phase of pour-flush latrine brick corrugated metal privacy structure.....	82
Table B.6: LCA results for construction and use phase of composting latrine adobe fiber cement privacy structure.....	83
Table B.7: LCA results for construction phase of composting latrine brick corrugated metal privacy structure	84
Table B.8: LCA results for construction and use phase of biodigester latrine adobe fiber cement privacy structure.....	85
Table B.9: LCA results for biodigester latrine brick corrugated metal privacy structure.....	86

LIST OF FIGURES

Figure 1: Access to water and sanitation statistics and child mortality rates for Peru	3
Figure 2: The influence of time and temperature on a variety of excreted pathogens	11
Figure 3: Components of a VIP latrine	16
Figure 4: Two-vault composting latrine.....	17
Figure 5: Pour-flush latrine with off-set collection pit.....	18
Figure 6: Diagram of Taiwanese style household biodigester latrine	19
Figure 7: Photo of Taiwanese style biodigester installed in Santo Domingo, Piura, Peru	20
Figure 8: Location of study site in Piura, Peru	22
Figure 9: System diagram showing the inputs and outputs for: (a) VIP latrine (b) pour-flush latrine (c) composting latrine and (d) biodigester latrine	25
Figure 10: LCA framework used in this study for materials associated with the four household sanitation technologies	27
Figure 11: Diagram of VIP latrine showing different theoretical layers.....	33
Figure 12: (a) Cumulative energy demand and (b) global warming potential of construction phase of sanitation systems.....	39
Figure 13: Cumulative energy demand of four sanitation systems over a 20-year period (a) without resource recovery and (b) with resource recovery	41
Figure 14: Global warming potential of four sanitation systems over a 20-year period (a) without resource recovery and (b) with resource recovery	44
Figure 15: Contribution of materials and biogenic emissions to global warming potential for each sanitation system	46
Figure 16: Cumulative energy demand of household and community level sanitation systems per household over 20-year period (a) without resource recovery and (b) with resource recovery	48
Figure 17: Global warming potential of household and community level sanitation systems per household over 20-year period (a) without resource recovery and (b) with resource recovery	49

ABSTRACT

Over seventy percent of the 2.5 billion people who still lack access to basic sanitation worldwide live in rural areas (WHO/UNICEF, 2012). Despite concerns of water scarcity, resource depletion, and climate change little research has been conducted on the environmental sustainability of household sanitation technologies common in rural areas of developing countries or the potential of resource recovery to mitigate the environmental impacts of these systems. The environmental sustainability, in terms of embodied energy and carbon footprint, was analyzed for four household sanitation systems: (1) Ventilated Improved Pit (VIP) latrine, (2) pour-flush latrine, (3) composting latrine, and (4) biodigester latrine. Variations in design and construction materials used change the embodied energy of the systems. It was found that systems that used clay brick in the construction of the superstructure had an average cumulative energy demand 4,307 MJ and a global warming potential 362 kilograms of greenhouse gas equivalent ($\text{kgCO}_2 \text{ eq}$) higher than systems that used adobe brick in the construction of the superstructure. It was also found that systems that incorporate resource recovery, such as a composting or biodigester latrine, can become net energy producers over their service life, recovering between 29,333 and 253,190 MJ over a 20-year period, compared to the 11,275 to 19,990 MJ required for their construction and maintenance. Recovering the resources from the waste also significantly lowered the global warming potential of these systems from 2,079-49,655 $\text{kgCO}_2 \text{ eq}$ to 616-1,882 $\text{kgCO}_2 \text{ eq}$; significantly less than the global warming potential of VIP latrine or pour-flush latrines (8,642-15,789 $\text{kgCO}_2 \text{ eq}$). In addition, two community wastewater treatment systems that serve 420-1,039 individuals considered in a similar study had a higher cumulative energy demand per household (44,869 MJ and 38,403 MJ) than the household sanitation systems (11,275-19,990 MJ). The community wastewater

treatment systems had a lower global warming potential (2019-2,092 kgCO₂ eq) than household systems that did not recover resources (8,642-15,789 kg CO₂ eq), but higher than household systems that incorporate resource recovery (616-1,882 kgCO₂ eq). The goal of this study is to provide insight to policy makers in the development field to promote decision making based on environmental sustainability in the implementation of improved sanitation coverage in rural areas of developing countries.

CHAPTER 1: INTRODUCTION

1.1 Research Motivation

2.5 billion people currently lack access to basic sanitation worldwide (WHO/UNICEF, 2012). The United Nations (UN) Millennium Development Goal (MDG) 7 Target 3 seeks to halve this number of people not served by improved sanitation by 2015 while ensuring environmental sustainability (UN, 2006). Although significant progress has been made, the world is likely to fall short of this goal. In addition, increasing greenhouse gas (GHG) concentrations and projected anthropogenic climate change appear likely to negatively impact sustainable development (IPCC, 2007). Water use is a major component of environmental sustainability and 70% of the world's fresh water is already used for irrigation (Zimmerman et al., 2008). Furthermore, agricultural production, water, and energy use will continue to increase as the global population approaches an expected 9 billion people in 2050 (FAO, 2011). Health and economic factors are commonly used to evaluate sanitation systems; however, this study provides an environmental sustainability context that, as part of a holistic approach, can be used when considering the improvement of sanitation coverage in developing countries and around the world. This is part of a new paradigm that has emerged in wastewater treatment where the sanitation systems are now viewed as resource recovery systems (RSSs), that should allow the perceived negative impact of wastewater to become a net positive impact (Guest et al., 2009).

The relationship between sanitation, water quality, and health has long been recognized as a valuable topic for academic research, professional journals, and international funding (e.g., Clasen and Bastable, 2003; Clasen et al., 2007; Fry et al., 2010; CDC, 2012). For example, the World Health Organization (WHO) estimates that consumption of contaminated water and lack of sanitation and hygiene account for 3.2% of deaths and 4.2% of Disability Adjusted Life Years

(DALYs) associated with diarrheal diseases worldwide (WHO, 2009). Table 1 provides mortality and the percent of DALYs attributable to diarrheal disease globally and regionally. This table shows there are an estimated 4 billion cases of diarrheal disease worldwide per year (Kosek et al., 2003), resulting in 2 million deaths (WHO, 2008). In addition, diarrhea accounts for 17% of all deaths in children under the age of 5 in developing countries (UN, 2006).

Table 1: Burden of diarrheal disease by global region, 2000. Source: Nath et al. (2006)

Deaths and DALY Totals for 2000							
	Global	Africa	Americ as	Southe ast Asia	Europe	East Mediter ranean	West Pacific
% Mortality due to Diarrheal Disease	3.2%	6.6%	0.9%	4.1%	0.2%	6.2%	1.2%
% DALYs due to Diarrheal Disease	4.2%	6.4%	1.6%	4.8%	0.5%	6.2%	2.5%

The Center for Disease Control (CDC) (2012) states that access to safe water and sanitation facilities (e.g. latrines), as well as knowledge of proper hygiene practices, can reduce the risk of illness and death from waterborne diseases, leading to improved health, poverty reduction, and socio-economic development. Despite recent gains in both rural and urban areas in developing countries, rural areas still lag behind significantly in terms of access to an improved water source and sanitation. As seen in Figure 1, in 2010 65% of the rural Peruvian population had access to an improved water source and 37% had access to improved sanitation. The modest gains in each indicator from 1990 to 2010 coincide with reduction of the under-5 mortality rate in Peru from 75 to 19.4 deaths per 1,000 births (World Bank, 2013). While this does not signify a direct correlation, many studies have suggested that a correlation does

exist between improved water and sanitation services and under-5 mortality rates (Sobsey et al., 2003).

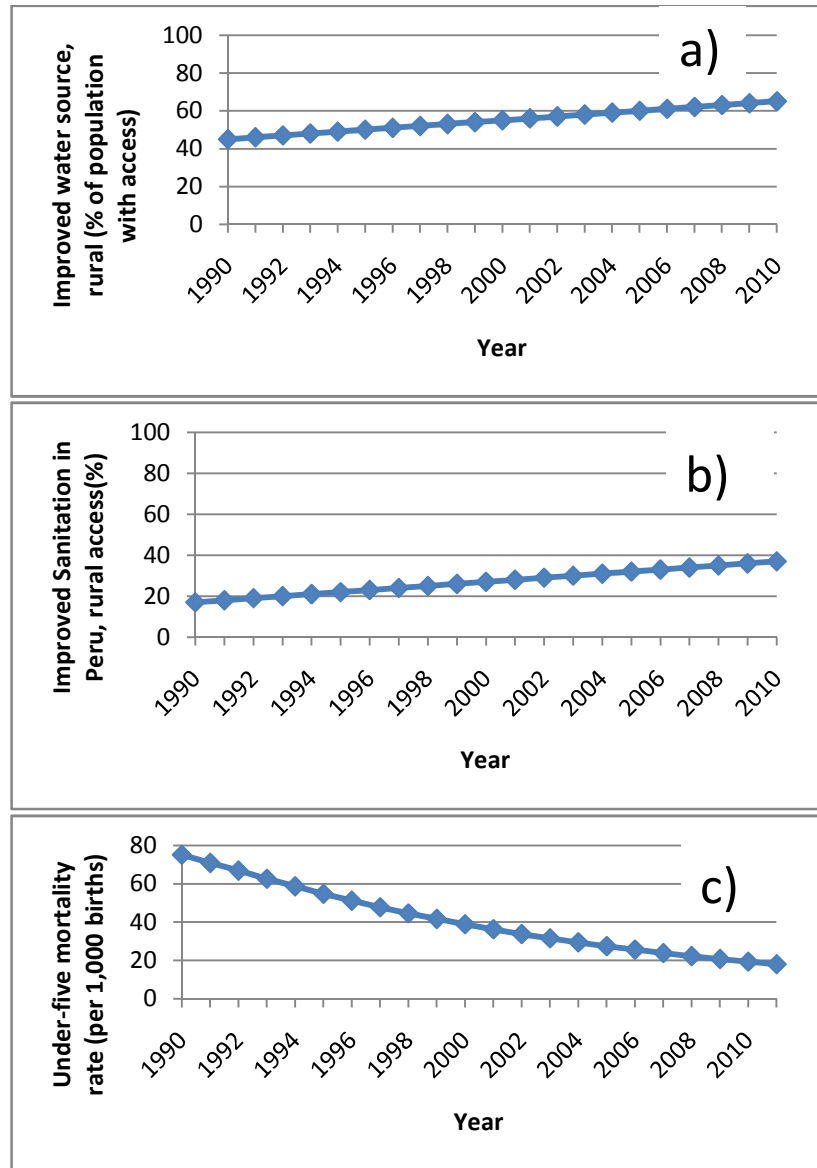

Figure 1: Access to water and sanitation statistics and child mortality rates for Peru. (a) Percent of Peruvian population with access to improved sanitation.(b) Percent of Peruvian population with access to improved water source. (c) Under-five mortality rate per 1,000 births for Peru. Source: World Bank (2013).

The primary function of sanitation systems is to protect human health by containing and/or treating human waste and its associated pathogen content. However, the effect of these systems on human health is not considered in this study, rather the environmental sustainability

of household sanitation systems is analyzed in terms of the amount of embodied energy and greenhouse gas (GHG) emissions associated with particular sanitation technologies, some which include resource recovery as a design objective.

1.2 Objective and Hypotheses

In this study, a Life Cycle Assessment (LCA) is performed on four household sanitation systems found in the region of Alto-Piura, Peru. Some of the sanitation technologies evaluated in this study are integrated with resource recovery. The sanitation systems are assessed and compared quantitatively for their environmental sustainability in terms of embodied energy (MJ) and carbon footprint (kgCO₂ eq). Although these household systems have a relatively small environmental impact individually when compared to other wastewater treatment systems, especially in developed countries, when extrapolated over the 2.5 billion people who currently lack access to improved sanitation worldwide (WHO/UNICEF 2012), their implementation may be significant on a regional or global scale. This study also compares the results of the environmental sustainability of household sanitation systems to the results from a study performed in rural Bolivia on small community-managed sanitation systems designed to serve between 700 and 1,500 people employing wastewater lagoons and anaerobic reactors. This provides an evaluation of the influence that scale of the sanitation technology will have on the environmental sustainability of sanitation coverage in developing countries. Accordingly, two hypotheses were developed for this research.

1. Although they will have higher Cumulative Energy Demand (CED) due to increased material requirements during installation and maintenance, sanitation systems such as composting latrines and biodigester latrines that incorporate energy recovery will have lower Global Warming Potential (GWP) over their service life when compared to ventilated improved pit (VIP) latrines and pour-flush latrines.

2. Because of the high amount of energy associated with installation and maintenance of community waste collection systems, it is expected that decentralized household level collection and treatment systems will have comparatively lower CED per household than a centralized waste collection system.

CHAPTER 2: PREVIOUS RESEARCH AND BACKGROUND INFORMATION

2.1 Nutrient Content of Human Excreta

Resource and energy recovery can play an important role in helping to reduce the energy, costs, and resources of wastewater treatment. Table 2 provides the basic characteristics of human excreta. This table shows that the average person produces 500 kg of urine and 50 kg of feces per year, containing 5.7 kg of nitrogen, 0.6 kg of phosphorus, and 1.2 kg of potassium (Heinonen-Tanski and van Wijk-Sijbesma, 2005). Recycling all the nutrients in domestic wastewater could reduce the global use of commercial fertilizers by 35-45% (Lind et al., 2001). One study quantified the amount of phosphorus produced in human excreta (urine and feces) worldwide as being 1.6 million metric tons in 2009, which corresponds to approximately 22% the global phosphorus demand (Mihelcic et al., 2011). In addition, Verbyla et al. (2013) estimate that the effluent of two community wastewater treatment plants in Bolivia contain the same amount of nutrients as the fertilizer used to produce crops containing 10-75 days' worth of the recommended food energy intake for each person discharging waste to the system. Recovery of the nutrients found in human waste thus has a great potential as a more sustainable strategy to offset commercial fertilizer needs.

Table 2: Characteristics of daily human excreta per person. Adapted from Esrey (2000).

Elements	Urine (grams/capita-day)	Feces (grams/capita-day)	Urine + Feces (grams/capita-day)
Nitrogen	11.0	1.55	12.5
Phosphorus	1.0	0.5	1.5
Potassium	2.5	1.0	3.5
Organic Carbon	6.6	21.4	30
Wet weight	1,200	70-140	1,200-1,400
Dry weight	60	35	95

2.2 Anaerobic Digestion

One common wastewater treatment strategy for energy and resource recovery in tropical and sub-tropical climates is the anaerobic digestion of wasted solids from the activated sludge treatment process. This strategy provides two benefits: (1) biogas is generated, which can be combusted to produce heat and electricity and (2) fertilizer can be processed from the biosolids, and is often marketed as a substitute to commercial fertilizers. For example, the 54.2 million gallon per day Howard F. Curren, advanced wastewater treatment plant (WWTP) in Tampa, FL, uses biogas powered generators to produce 36,000 kWh of energy per day, approximately 25% of the plant's energy use. Additionally, 22.2 dry tons of processed sludge are harvested per day for land application (City of Tampa, 2012). Anaerobic processing of industrial waste and municipal wastewater is not limited to the U.S. and it is also common in countries such as Brazil, China, India, Colombia and Mexico, as a way to improve sanitation infrastructure and recover valuable resources. For instance, 85 Upflow Anaerobic Sludge Blanket (UASB) wastewater treatment plants were constructed in Mexico between 1987 and 1998 (Monroy et al., 2000).

Energy and resource recovery through anaerobic digestion is also possible at the household level. Numerous studies have examined household biodigestion as a means of management of human and agricultural wastes in developing countries due to their potential for energy and resource recovery (Gunnerson and Stuckey, 1983; GTZ, 1999; Buysman, 2009; Walekhwa et al., 2009; Ocwieja, 2010; Rowse, 2011). For example, Chen et al. (2010) report that as of 2007, 26.5 million household biodigesters using pig, human, and agricultural waste feed have been built in China. From 1991 to 2005 an estimated 833,000 TJ of energy was produced by these systems in China, resulting in a reduction of greenhouse gases (GHG) emissions of 73,200 Gg CO₂ equivalents (Yu et al., 2008). Another study found that users in the Liangshui and Guichi counties of China used 2,175 kWh (7,831 MJ) per year from biogas per household (Xiaohua et al., 2007).

Resource recovery from the biodigester is also associated with the use of the nutrient rich effluent as fertilizer. Nutrient concentrations in the effluent vary widely depending on influent concentrations and management practices, such as collection method, flush water, bedding, and dilution rate. Table 3 provides values found in literature of nutrient concentrations of potential biodigester feed materials. Although nitrogen does undergo a chemical transformation from the organic form to a mineral form, in general, plant nutrients such as nitrogen, phosphorus, and potassium are conserved during anaerobic digestion. The reduction in total Kjeldahl nitrogen as a result of anaerobic digestion reported in several studies is likely due to the fact that only the supernatant is analyzed for nitrogen content of the effluent and solids contain 34.5% of the total nitrogen of the effluent (Massé et al., 2007).

Table 3: Nutrient concentrations of potential biodigester feeds.

	Nitrogen (mg N/L)	Phosphorus (mg P/L)	Potassium (mg/L)	Source
Fresh cow manure	12,000	1,700	1,100	(FAO, 2005)
	5,730	1,140	3,130	(USDA, 2008)
	6,620	1,150	1,520	(ASAE, 2005)
Poultry	22,000	18,000	11,000	(FAO, 2005)
	18,100	5,700	6,730	(USDA, 2008)
Swine	7,080	2,080	4,420	(ASAE, 2005)
	7,440	2,150	4,700	(USDA, 2008)
Human Feces	7,000	2,330	4,670	(Esrey, 2000)

Several studies have also investigated the effectiveness of biodigestion with respect to the elimination of pathogens commonly found in wastewater. Although many bacteria can survive prolonged periods in an anaerobic environment, small scale biodigesters have been found to effectively remove pathogens, such as *Salmonella Typhi* and *Escheria Coli*, based on the operating temperature and retention time (Côté et al., 2006). Temperature is an important

operational parameter in terms of how pathogens are destroyed during anaerobic digestion. For example, destruction times of pathogens are generally represented in months in the psychrophilic range (-10 to 15°C), days in the mesophilic range (20 to 45°C), and hours in the thermophilic range (45 to 120°C) (Sahlström, 2003). Residence time of the waste is also important. For example, Taiwanese-style biodigesters typically operate with a 45-day solids retention time in the mesophilic range (Gunnerson and Stuckey, 1986). In addition, a laboratory experiment of batch anaerobic digestion found that all *Salmonella* was removed after 15 days at 35°C or after 25 days at room temperature and 99.6% of *E. coli* was removed in 5 days at 35°C (Kumar et al., 1999). Another field study measured zero coliform forming units (CFU) in the effluent of a Taiwanese style biodigester operated with a 50-day solids retention time (Botero and Preston, 1987).

Furthermore, Massé et al. (2011) found that although the majority of pathogens found in swine waste (e.g. *Salmonella*, *Campylobacter* spp., and *Yersinia enterocolitica*) were reduced below detectable levels when treated by psychrophilic sequenced batch reactors; however, *Clostridium perfringens* and *Enterococcus* spp levels remained high within the digesters throughout treatment. Although research shows the substantial removal of pathogens from waste through anaerobic digestion, proper waste management should be used to reduce the risk associated with use of effluent in agriculture, especially when human waste is digested.

2.3 Pathogen Destruction in Composting Latrines

Composting latrines have been promoted by development organizations as a sanitation technology with the added benefit of resource recovery through organic fertilizer production. However, social acceptability of this technology varies in different parts of world. For example, in China and Southeast Asia the use of human excreta as agricultural fertilizer has been common for thousands of years. One study found that 75% of farmers surveyed in central Vietnam reported using fresh or partially composted human feces to fertilize their farmland or garden

(Jensen et al., 2013). In contrast, acceptability of composting latrines in other parts of the world such as Africa and Central and South America may be lower and depend strongly on the education and training aspects of individual projects (Karlsson and Larsson, 2000; Hurtado, 2005).

Elimination of pathogens in feces is dependent upon a few important environmental factors in the latrine: temperature, time, pH, and moisture content. Figure 2 provides the time and temperature required to destroy certain pathogens. Heat is a by-product of aerobic decomposition and Vinneras et al. (2003) found that an insulated composting latrine can reach temperatures above 60°C and successfully eliminate pathogens. Hurtado (2005) and Kaiser (2006) warn that composting latrines in the field may operate at ambient temperatures, but still may effectively remove pathogens due to elevated pH (Kaiser, 2006). Furthermore, a field study and laboratory analysis of 63 composting latrines in Panama found latrines operating at an average temperature of 29.5°C, compared to 29°C average ambient temperature. These latrines did not sufficiently eliminate pathogens when operated with a six month storage times; therefore, a one year storage period was recommended instead (Mehl et al., 2011). Table 4 provides the results of the microbiological analysis of five compost samples from the study by Mehl et al. (2011). Pathogens, such as *Ascaris lumbricoides* which is commonly used as an organism of concern in pathogen removal studies, were present in many of the samples.

Several studies have determined that in order to improved aerobic decomposition in a composting latrine, the addition of desiccant after each use is necessary to not only desiccate pathogens, but also raise the carbon to nitrogen (C:N) ratio to the ideal ratio of 15:1 to 30:1 (Karlsson and Larsson, 2000; Mehl et al., 2011). The C:N ratio of wood ash and saw dust, commonly used desiccants, are 25:1 and 200-500:1, respectively. Untreated human feces have approximately a 5:1 C:N ratio, while finished compost has a 10:1 C:N ratio (Richard and Trautmann, 1996). Often insufficient desiccant is added by the users to raise the ratio to the recommended value as seen in Table 5. The additional nutrients found in compost increased

the yield of covo, spinach, lettuce and onions by 300-700% in field trials in Mozambique using composted human feces in a 50:50 mixture with regular soil (Morgan, 2007).

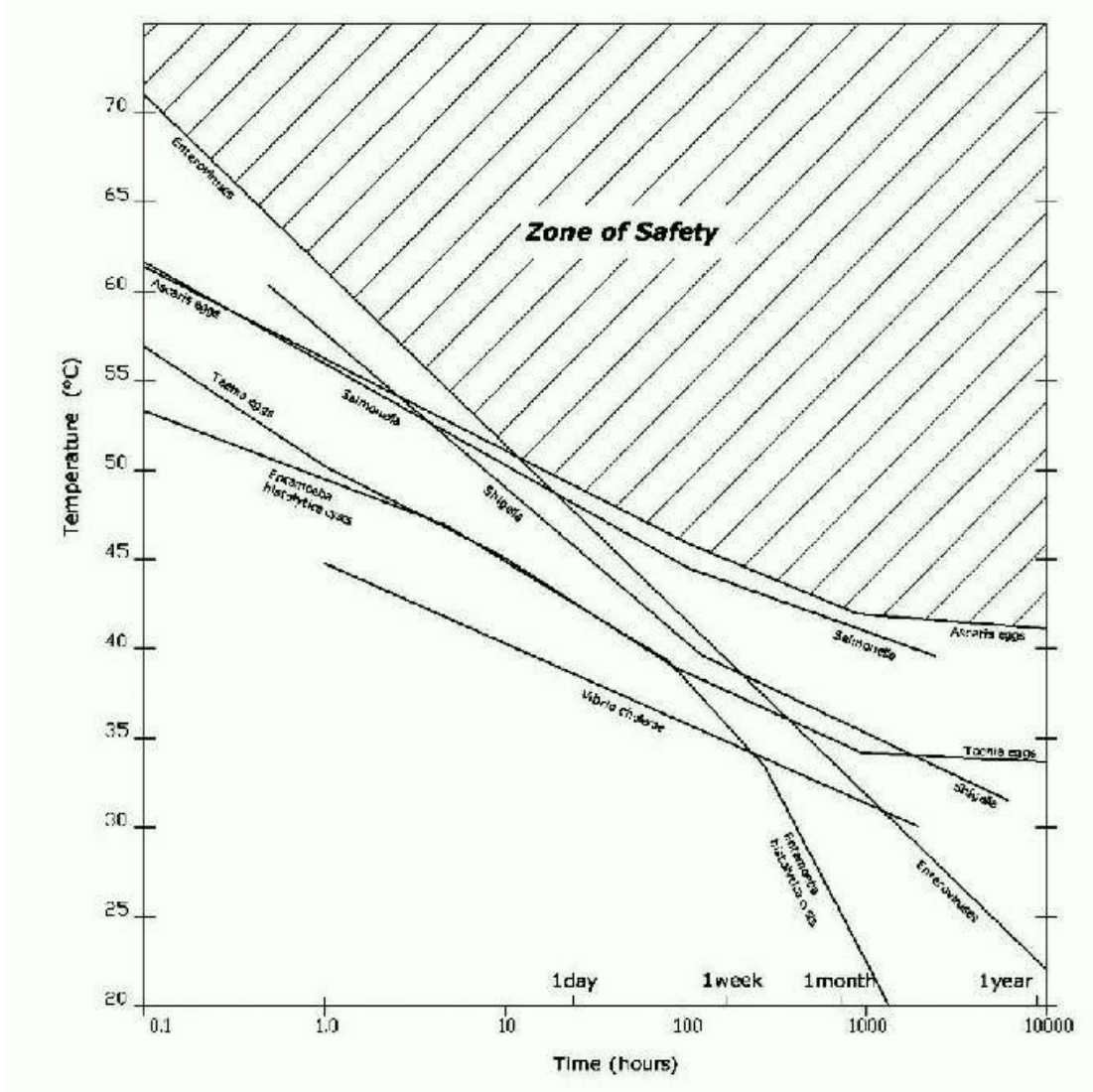

Figure 2: The influence of time and temperature on a variety of excreted pathogens. The lines drawn represent conservative upper boundaries for death. Source: Cairncross and Feachem (1993) with permission.

Table 4: Microbiological analysis of five samples obtained from active compost latrines in Panama. (N/O = Not Observed) Data from Mehl et al. (2011).

Sample	Bacteria					Helminths				Protozoa	
	Total coliforms (CFU/100 g)	<i>E. coli</i>	<i>Salmonella</i>	<i>Shigella</i>	<i>Klebsiella</i> (CFU/100 g)	<i>Taeniasolium</i>	<i>Taeniasaginata</i>	<i>Ascaris lumbricoides</i>	<i>Trichuris trichura</i>	<i>Entamoeba</i>	<i>Giardia lamblia</i>
A	8.E+04	N/O	N/O	N/O	N/O	N/O	N/O	infertile egg	infective egg	Entamoeba colicyst	N/O
B	7.E+03	N/O	N/O	N/O	N/O	eggs	N/O	infertile egg	N/O	N/O	N/O
C	3.E+04	N/O	N/O	N/O	4.E+03	adult sections and eggs	N/O	egg	N/O	N/O	N/O
D	3.E+04	N/O	N/O	N/O	6.E+03	N/O	N/O	fertile egg	N/O	N/O	N/O
E	7.E+04	N/O	N/O	N/O	N/O	N/O	N/O	infertile egg	N/O	N/O	N/O

Table 5: Chemical composition of compost samples. Adapted from Mehl et al. (2011).

Sample	pH	Moisture content (%)	C (%)	N (%)	C:N	P (%)	K (%)
A	9.18	36.7	2.03	0.35	5.8	0.24	2.79
B	9.45	29.5	1.93	0.36	5.4	0.24	3.62
C	9.48	66.8	19.85	2.34	8.5	0.46	3.13
D	6.46	49.6	12.92	1.41	9.2	0.41	1.58
E	8.45	46.7	6.19	0.89	7	0.41	3.06

2.4 Life Cycle Assessments Related to Water and Wastewater

Life cycle assessment (LCA) is a tool for quantitatively analyzing processes or products for their environmental impact, including the life stages of raw material extraction, transport, construction, use, and end-of-life phases (EPA, 2006). An important engineering process now being analyzed with LCA is the treatment and distribution of water, which accounts for 2-3% of

the world's total energy demand (James et al., 2002) and 3% in the U.S. (EPA, 2008b). The goal of applying the LCA method to wastewater treatment technology is to quantify energy and resource consumption within the process and identify opportunities to improve the overall environmental sustainability.

Cumulative energy demand in megajoules (MJ) and carbon footprint in kilograms of greenhouse gas equivalent (kgCO₂ eq) are commonly used to quantify the results of an LCA and allow for comparison with other studies. However, the majority of current studies have focused on large scale facilities in developed countries (100+ MGD wastewater treatment plants) and there is little research available on smaller systems in developing countries. For example, Mo and Zhang (2012) analyzed the potential benefits of integrated resource recovery of energy, nutrients, and water at the 54.2 MGD Howard F. Curren advanced WWTP in Tampa, FL. It was found that on-site energy generation from biogas, land application of digested sludge, and water reuse for residential irrigation together could offset all direct operational energy of the plant (accounting for 90% of its total embodied energy and carbon footprint of the plant), but not the total embodied energy of the plant (which includes the construction phase). Another study compared direct, indirect, and total embodied energy of two drinking water treatment plants in the U.S., one in Tampa, FL using surface water as its source and the other in Kalamazoo, MI using groundwater as a source. It found that the two plants had comparable total embodied energy per volume of water provided (10.3 MJ/m³ for the groundwater plant and 10.7 MJ/m³ for the surface water plant). However, the groundwater plant had higher direct energy usage due to increased pumping requirements while the surface water plant had higher indirect energy usage due to the additional treatment and chemicals required for the lower quality raw water source (Mo et al., 2011).

A study in rural Bolivia compared the cumulative energy demand and GHG emissions over a 20-year period of two community wastewater treatment systems serving between 420-1,039 users with different water reuse and energy recovery conditions. It was determined that

for an existing Upflow Anaerobic Sludge Blanket (UASB) reactor, the addition of energy recovery from biogas would reduce the carbon footprint by 57.2% compared to the existing condition. In comparison, reuse of effluent for a three-pond wastewater treatment system would reduce the carbon footprint by 0.1-2.1% compared to river water irrigation (Cornejo et al., 2013). In another study investigating the economic, social, and environmental sustainability of community wastewater treatment facilities, basic treatment methods, such as lagoons, were determined to be more appropriate than mechanical treatment methods, such as activated sludge (Muga and Mihelcic, 2008). In many rural areas, community systems that include a collection system and treatment lagoons are not feasible due to cost, community size, low population density, geography, lack of funding for infrastructure, and/or inability to operate and maintain the facility (IPCC, 2007). In this case, household level systems may be more appropriate. In order to meet the United Nations MDG 7 target for improved sanitation coverage many more household sanitation systems will need to be constructed. When considered on a global scale, this represents a large investment of finite resources, especially for local or regional governments of developing countries.

One study was identified that analyzed the embodied energy of eight water supply interventions in Sub-Saharan Africa (four source level and four household level) (Held et al. 2012). Table 6 provides the embodied energy of these interventions. Human energy was included in the calculation of the embodied energy and, although it is typically considered negligible in this type of analysis, accounted for over 90% of the total embodied energy in four of the eight interventions. When the human energy is segregated by gender it shows that over 99% is provided by women (mainly during the use phase) and 1% by men (mainly during the construction phase) for seven of the eight interventions.

Table 6: Embodied energy of eight water supply interventions in Mali. Adapted from Held et al. (2012).

Intervention	Intervention type	Embodied Energy (GJ per functional unit)
Rope pump	Source protection	117
Chlorination	Point of use	131
Improved well	Source protection	134
Biosand filter	Point of use	139
India Mark II hand pump	Source protection	245
Solar pump	Source protection	302
Ceramic filter	Point of use	343
Boiling with fuelwood	Point of use	172,559

2.5 Sanitation Technologies Evaluated in this Study

2.5.1 Ventilated Improved Pit Latrine

The Ventilated Improved Pit (VIP) latrine is a relatively basic sanitation technology common in rural areas of developing countries due to its low cost and ease of maintenance. Similar to the standard pit latrine, it consists of three parts: (1) the pit, (2) the platform, and (3) the superstructure (see Figure 3). Materials used to construct the privacy structure can vary, depending on local preferences and availability; however, adobe brick, clay brick, or corrugated metal are common. The VIP latrine should be oriented so the prevailing wind enters the pit through the superstructure and exits through the ventilation tube, suppressing unpleasant odors inside. Additionally, the ventilation tube is placed where it will be heated by sunlight to promote the upward flow of air out of the pit. The pit may be lined or unlined, depending on soil type. The service life can be estimated with the following formula:

$$Service\ life = \frac{Crosssectional\ area * Pit\ depth}{Number\ of\ users * Accumulation\ rate}$$

The accumulation rate is typically 0.2-0.9 m³/capita-year depending on the pit's contact with the water table and the anal cleansing materials used (Mihelcic et al., 2009). When the pit is around 80% full (typically around 30 cm from the slab) a new pit should be dug and the latrine relocated, reusing the materials in the privacy structure if possible. The original pit should be

capped with soil to prevent contamination of the surrounding area and is an ideal location for planting a fruit tree to take advantage of the nutrients of the waste left in the pit.

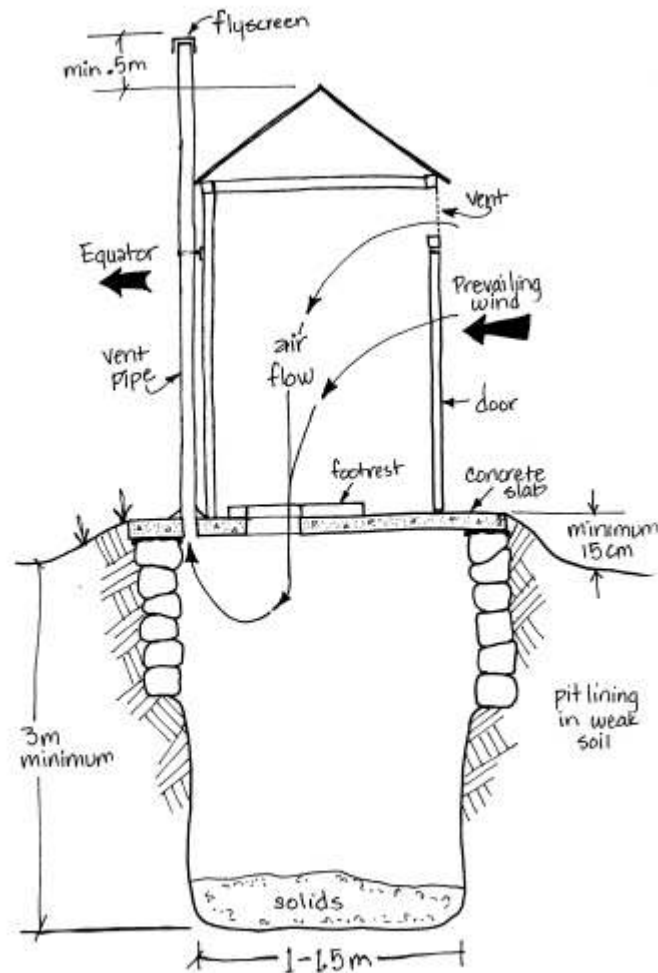

Figure 3: Components of a VIP latrine. Source: Figure from Mihelcic et al. (2009) with permission provided by Linda A. Phillips.

2.5.2 Composting Latrine

The composting latrine is a household sanitation option that converts human excrement to a soil amendment which improves the physical structure and nutrient content of soil. Because the latrine is constructed above ground and sealed, it can be built in areas with high ground water tables or close to surface water sources without risk from seasonal flooding. A double vault latrine is usually constructed as shown in Figure 4. The vaults are used alternately-- so

while one is in use, the waste in the other is being composted. The urine diversion style (as seen on the right of Figure 4) has a separator seat which transports the urine outside of the latrine where it may be collected (as considered in this study) or can be allowed to drain into a soak pit. Diverting the urine promotes the decomposition of the feces in two ways: (1) by lowering its moisture content and increasing oxygen transfer within the compost and (2) by raising the C:N ratio of the compost by isolating the nitrogen found in urine from the composting feces. The urine is also easily reused as fertilizer (Shaw, 2010). Composting latrines require specific use and maintenance to ensure their proper functioning. For example, a dry organic desiccant must be kept on hand for addition after each use and the compost removed when it is ready for harvesting (i.e., annually).

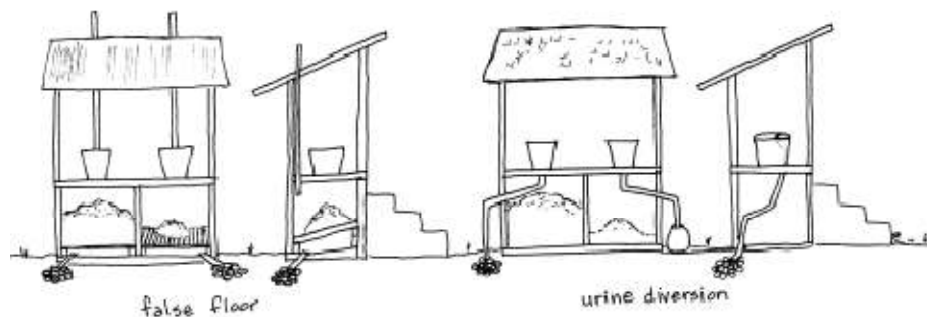

Figure 4: Two-vault composting latrine. Source: Figure from Mihelcic et al. (2009) with permission provided by Linda A. Phillips.

2.5.3 Pour-Flush Latrine

The pour-flush latrine uses water to flush solids from the bowl to a collection pit. It is popular in many developing countries because it resembles the indoor system found in sewered communities commonly seen in urban areas. The design is typically covered with a reinforced concrete slab and can incorporate a squatting or traditional style seat. The bowl has water seal trap (see Figure 5) that prevents flies from entering the pit and odors from passing into the latrine. The pit is lined but not sealed (i.e., spaces are left between the bricks) allowing the liquids to permeate to the surrounding soil while retaining the solids. Outside of this lining there

is 10 cm of gravel which filters the liquid and helps to ensure proper drainage to the soil. Overall, pour-flush latrines are appropriate in areas with reliable, year-round water supply that can accommodate the extra water usage associated with flushing the latrine.

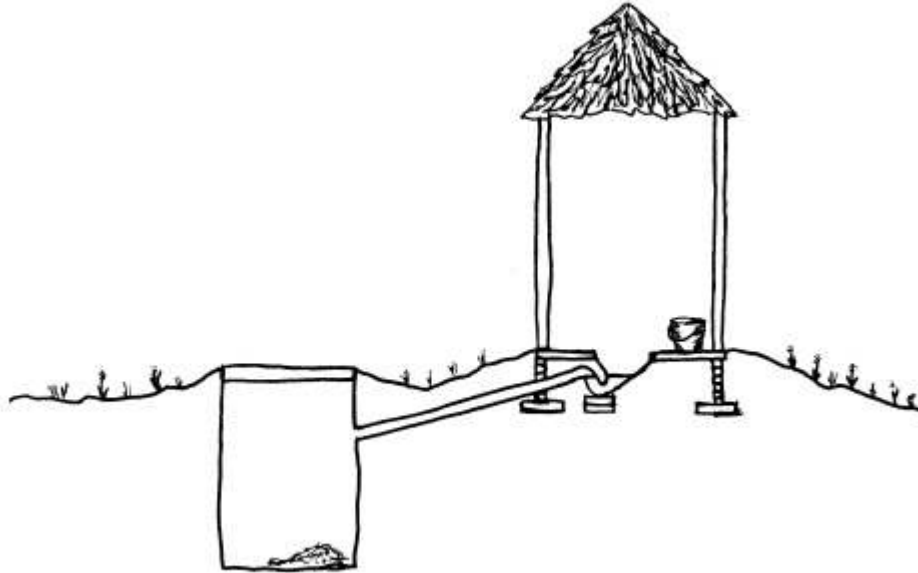

Figure 5: Pour-flush latrine with off-set collection pit. Source: Figure from Mihelcic et al. (2009) with permission provided by Linda A. Phillips.

2.5.4 Biodigester Latrine

Figure 6 provides a diagram of a household biodigester latrine using a Taiwanese flexible bag-style digester. Figure 7 provides a photo of what this type of biodigester looks like in the field. This system is operated semi-continuously with inputs from both the household flush latrine and manually mixed slurry from cow manure. A solids retention time of 45 days is recommended to allow time for proper functioning of the reactor. As the reactor is filled the entrance and exit pipes are sealed by the contained slurry, preventing air from entering the reactor and allowing the anaerobic digestion process to take place. This initial loading of the reactor is referred to as “charging” the digester and consists of a period of 2-3 weeks of operation while the anaerobic bacteria and archaea involved in methanogenesis (production of

methane) multiply and produce biogas. The reactor and reservoir are made from a geomembrane PVC and inflate to a sufficient pressure for the household use of biogas for cooking, lighting, or heating. In addition to the production of biogas, the biodigester produces a nutrient rich effluent which can be used as an agricultural fertilizer.

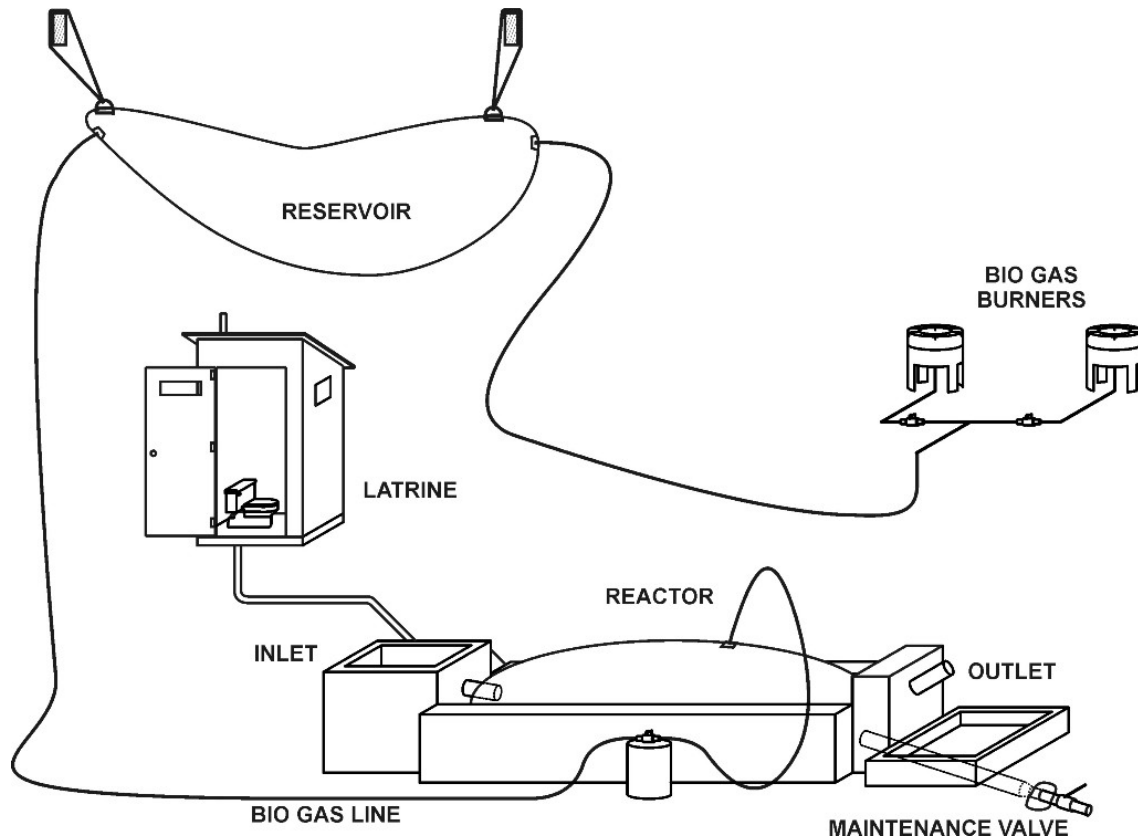

Figure 6: Diagram of Taiwanese style household biodigester latrine.



Figure 7: Photo of Taiwanese biodigester installed in Santo Domingo, Piura, Peru (photo from Christopher Galvin).

CHAPTER 3: METHODS

3.1 Goal and Scope Definition

The goal of this study is to quantitatively estimate and compare the environmental sustainability of four sanitation systems found in the Alto-Piura region of northern Peru, and common in rural areas of other developing countries. While each represents a relatively small use of resources or investment during construction and use phases, when extended over a regional, national, or global scale the results are significant. This study is intended to provide insight to policy makers in the development field interested in environmental sustainability and to provide reliable data related to local materials, culturally appropriate technology, energy and resource recovery, and water conservation.

3.2 Site Location

This study takes place in the department of Piura (Peru). As shown in Figure 8, the department of Piura is located in northern Peru on the western side of the Andes Mountains sharing a border with Ecuador.

Piura has a population of 1.6 million and is divided into 8 provinces and 64 districts and has an area of 35,893 km². Spanish is spoken exclusively in the area. The capital of the region is Piura which is the most populated city.

This study is based in the district of Santo Domingo in the region of Alto-Piura, 130 km east of the department capital. It has an area of 187.3 km² and a population of approximately 8,000. It is a highly rural district with 87% of the district population dispersed between 41 communities of 200 people or less, many of which are without road access or basic sanitation services. The district population has declined 14% since 1993, primarily due to emigration (Municipality of Santo Domingo, 2008).



Figure 8: Location of study site in Piura, Peru.

Various strategies and latrine designs have been implemented in Santo Domingo by the national government, local municipality, and international NGOs. Four types of latrines have been chosen for life cycle assessment in this study: (1) Ventilated Improved Pit (VIP) latrine, (2) pour-flush latrine, (3) composting latrine, (4) biogas digester latrine. All four are sanitation systems designed to protect human health while the third and fourth also incorporate energy/resource recovery options. Table 7 provides the basic characteristics of the four latrines considered in this study.

Table 7: Basic characteristics of the four latrine technologies considered in this study.

	VIP Latrine	Pour-Flush Latrine	Composting Latrine	Biodigester Latrine
Estimated cost (USD) (20 years)	135.34	893.20	495.38	2065.79
Operational Maintenance	Minimal	Medium	High	High
Expected life	10 years	10 years	20 years	7 years
Water use	None	1-5 L per flush	None	1-5 L per flush
Mechanism to protect human health	Containment	Containment	Containment and Pathogen Destruction	Containment and Pathogen Destruction
Resource recovery	No	No	Yes, compost and urine diversion	Yes, biogas and effluent

3.3 Defining the Functional Unit and System Boundary

The functional unit for this study is based on the primary function of the sanitation systems which is the containment and treatment of human waste (urine and feces) produced by one household-equivalent over a 20-year period. Demographic data reports an average of 5.05 people per household in the study location (Municipality of Santo Domingo, 2008). The treatment of cow manure that is added to the biodigester is a secondary function of this system, and therefore the cow manure is considered an additional input to the system apart from the functional unit.

A flowchart of the inputs and outputs for the use phase of each sanitation system is provided in Figure 9. The VIP latrine and pour-flush latrine systems are relatively less complex with the human waste being degraded to carbon dioxide and methane emissions to air. The composting latrine and biodigester latrine outputs vary slightly depending on the operation. For example, the composting latrine may or may not be used to recover the nutrients (nitrogen, in this case) in feces and urine. In the case of the biodigester latrine, its operation affects the biogenic emissions produced. Theoretically, the biogas is combusted and no methane is released; however, the escape of a certain portion of biogas is unavoidable (i.e., from the inlet

and outlet), especially if the system is operated improperly (i.e., operated with a leak in the gas system) or the biogas is not regularly used, methane may be directly emitted to air.

3.3.1 Data Collection and Life Cycle Inventory

Figure 10 provides the LCA framework for materials associated with the four sanitation technologies. The designs and project budgets for the VIP and composting latrine were provided by Peace Corps Peru through its technical library. The pour-flush latrine is currently being implemented by the municipality of Santo Domingo and its design was provided by civil engineer Cesar Castillo. Several Taiwanese style biodigesters have been installed in the study site; however, the biodigester latrine is based on literature on biodigesters used as household sanitation systems (Gunnerson and Stuckey, 1986; GTZ, 1999; Ocowieja, 2010) and developed in discussions between civil engineer Cesar Castillo and the author. Table 8 provides the model inputs, data sources, and inventory items used in the LCA in this study.

Material inventories were compiled for each system and entered in SimaPro 7.2 (PRé Consultants, 2008) using the Ecoinvent database (St. Gallen, Switzerland). Materials and processes used from the database, such as transport, were assumed to be the same for the study location.

3.4 Calculations for Life Cycle Inventory

3.4.1 Material Production

The total material mass that makes up a particular sanitation technology was estimated as follows:

$$\text{Mass of material } i \text{ (kg)} = \sum_{i=1}^n \text{Mass}_i * \text{Purchase frequency}_i \quad (1)$$

where mass is the weight (kg) of a particular material.

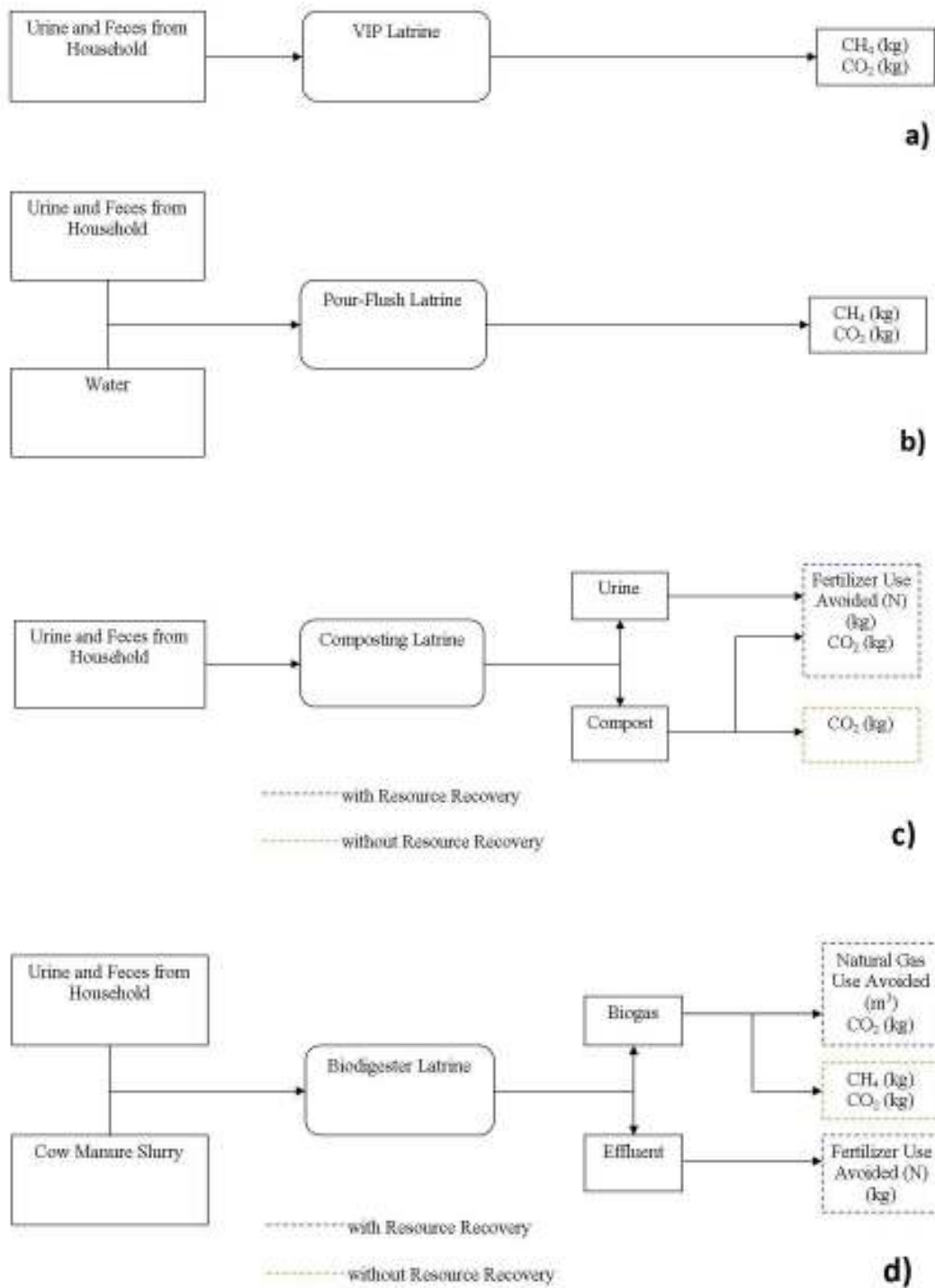

Figure 9: System diagram showing the inputs and outputs for: (a) VIP latrine (b) pour-flush latrine (c) composting latrine and (d) biodigester latrine.

The majority of the materials have a purchase frequency of one, because they do not need to be replaced over the 20-year system life. The geomembrane reactor and gas reservoir for the biodigester latrine were assumed to have a 7-year life (2.68 purchase frequency). The service lives of the VIP and pour-flush latrines are based on the amount of time for the pit to fill with accumulated solids, which was assumed to be 10 years. Therefore, the entire VIP latrine (superstructure and pit) must be reconstructed only once over the 20-year period and the materials associated with the construction have a purchase frequency of 2. In the case of the pour-flush latrine, the superstructure and plumbing are still serviceable if connected to a new pit; therefore, it is only necessary to construct a new collection pit once over a 20-year period. Thus the materials associated with the construction of a new collection pit (brick, cement, sand, gravel, and rebar) have a frequency of 2.

3.4.2 Material Delivery

Material delivery was determined in kg-kilometers (kg-km) for each system as follows:

$$\text{Delivery from location } i \text{ (kg-km)} = \sum_{i=1}^n \text{Mass}_i(\text{kg}) * \text{Distance}_i(\text{km}) \quad (2)$$

In Equation 2, mass is the weight (kg) of a particular material and distance is the distance the material is transported to the construction site. Some materials are available locally, such as water and wood, while others are produced in other locations and transported to the site location by truck. The truck capacity was assumed to be 3-16 tons based on the author's in country experience. Specific distances from material origin to the study location are provided in Table 9.

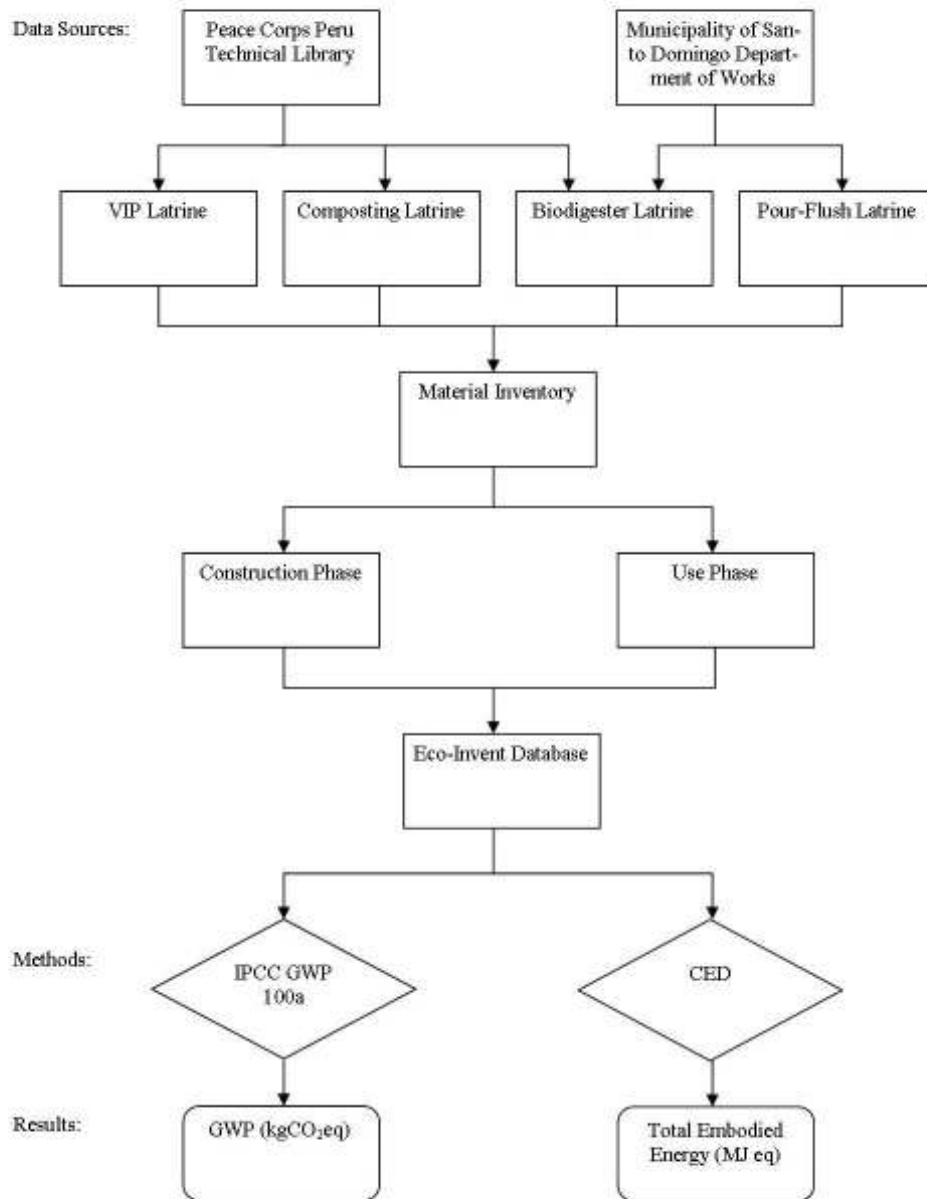

Figure 10: LCA framework used in this study for materials associated with the four household sanitation technologies.

Table 8: Model input data collected and SimaPro inputs (adapted from Stokes and Horvath, 2006)

Model Inputs	Data Sources	Inventory Items
<i>Material Production:</i> Material Type, Material Properties (kg or m ³), Service Life (years), Purchase Frequency (qty)	Source: Project documents: Budget VIP Latrines, Budget Composting Latrines, Budget Biodigester (Peace Corps Peru Technical Library); Cesar Castillo (Civil Engineer, Municipality of Santo Domingo) Contribution: Material production data	Mass (kg) or volume (m ³) of materials used over 20-year lifespan
<i>Material Delivery:</i> Material Origin (City), Distance (km), Cargo Weight (kg), Mode of Transportation (vehicle type)	Source: Project documents: Budget VIP Latrines, Budget Composting Latrines, Budget Biodigester (Peace Corps Peru Technical Library); Cesar Castillo (Civil Engineer, Municipality of Santo Domingo) Contribution: Material delivery data	Freight transportation quantity (kg-km) of materials delivered to site over 20-year lifespan
<i>Resource Recovery:</i> Volume (m ³) of natural gas avoided, Mass (kg) of fertilizer use avoided	Source: EPA (2010); Rittmann and McCarty (2001); ASAE (2005); Jönsson et al. (2004); Esrey (2000) Contribution: Production and energy content of biogas (m ³) by biodigester, nitrogen concentration in cow manure and human urine and feces	Volume (m ³) of natural gas avoided over 20-year lifespan, Mass of N (kg) of fertilizer use avoided over 20-year lifespan
<i>Biogenic Emissions:</i> Mass (kg) of carbon dioxide and methane	Source: EPA (2010) Contribution: Production of biogenic emissions by each system	Mass (kg) of carbon dioxide and methane over 20-year period

3.4.3 Biochemical Oxygen Demand Input

As can be seen previously in Figure 9, each system has the input of urine and feces from humans that occupy one household, while the input to the biodigester is augmented with cow manure slurry. A value of 80 g BOD/capita-day (Metcalf & Eddy, 2003) was used to calculate the organic loading per household in the following calculation:

$$80 \frac{g \text{ BOD}}{\text{capita} \cdot \text{day}} * 5.05 \frac{\text{people}}{\text{household}} * \frac{1 \text{ kg}}{10^3 \text{ g}} * \frac{365 \text{ days}}{1 \text{ year}} * 20 \text{ years} = 2,950 \frac{\text{kg BOD}}{\text{household}} \quad (3)$$

Table 9: Distances to site location from material origins.

	Distance (km) to site location Santo Domingo, Piura, Peru	Material
Local	0	water, wood
Morropon	45.5	sand, gravel
Buenos Aires	63.1	clay brick
Piura	130	PVC tubes and accessories
Pacasmayo	449	cement
Lima	1108	PVC geomembrane biodigester reactor and reservoir, rebar, corrugated metal

Values for latrine flush volume and frequency were obtained from Mihelcic et al. (2009) and were used to determine water use for the pour-flush and biodigester latrine:

$$2.5 \frac{L}{flush} * 5 \frac{flush}{day*person} * 5.05 \frac{people}{household} = 63.1 \frac{L}{household*day} \quad (4)$$

A 10-m³ biodigester with a 45-day solids retention time would have a flow rate of 222 L/day. 63.1 L/day are supplied by the latrine; therefore, 159 L of slurry (1:3 mixture of manure to water) should be added per day. Based on the value of 22.2 kg BOD/m³ for fresh manure (USDA, 2008) the total BOD content of the slurry for the 20-year period was determined as follows:

$$22.2 \frac{kg\ BOD}{m^3\ manure} * \frac{1\ m^3\ manure}{4\ m^3\ slurry} * 159 \frac{L\ slurry}{day} * \frac{1\ m^3}{10^3L} * \frac{365\ days}{1\ year} * 20\ y = 6440\ kg\ BOD \quad (5)$$

Therefore the total BOD input to the biodigester over 20 years was estimated to be 9,390 kg.

3.4.4 Anaerobic Degradation of Domestic Wastewater

The biochemical oxidation of the organic constituents found in wastewater through an anaerobic treatment process can be described by the following stoichiometric equation derived from Rittmann and McCarty (2001):

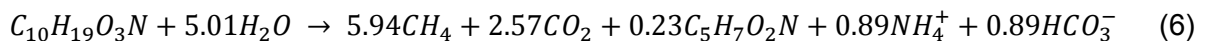

In Equation 6, domestic wastewater is assumed to be the electron donor and carbon dioxide the electron acceptor and the stoichiometric molar requirements of methane, carbon dioxide, and biomass per mole of BOD are also provided. The growth rate of the microorganisms in the anaerobic process is typically much lower than aerobic processes and methane makes up 60-70% of the biogas produced, while carbon dioxide makes up the other 30-40% with trace amounts of N₂, H₂, and H₂S (Rittmann and McCarty, 2001). As mentioned previously, this process is commonly used in wastewater treatment and is considered in this thesis in the calculation of biogenic emissions and biogas production.

3.4.5 Aerobic Degradation of Domestic Wastewater

In the presence of oxygen, the biochemical oxidation of domestic wastewater can be described by the following stoichiometric equation derived from Metcalf and Eddy (2003):

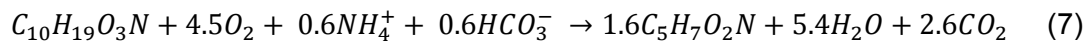

This reaction is commonly used to describe the treatment of organic matter found in municipal wastewater through the activated sludge process. The biomass is supplied with oxygen and grows in the aeration basin while converting organic carbon to CO₂. Typically the secondary clarifier settles and recycles the majority of the biomass back to the aeration basin. The reaction may also be applied to the degradation of waste in other systems, such as the upper region of a facultative lagoon or, as considered in this study, a composting latrine.

3.4.6 Biogenic Emissions

In general, biogenic emissions to air are associated with the decomposition of feces in both aerobic and anaerobic environments. Equations 6 and 7 provide the theoretical basis for the production of methane and carbon dioxide. For the purpose of comparing the results with those of Cornejo et al. (2013) the following method for calculating the biogenic air emissions obtained from the EPA (2010) was used to calculate the methane and carbon dioxide values:

$$CO_2 = BOD * Eff_{OD} * CF_{CO_2} * [(1 - MCF_{ww} * BG_{CH_4})(1 - \lambda)] \quad (8)$$

$$CH_4 = BOD * Eff_{OD} * CF_{CH_4} * [(MCF_{ww} * BG_{CH_4})(1 - \lambda)] \quad (9)$$

In Equations 8 and 9:

CO_2 = CO_2 emissions (kg) over 20 years

CH_4 = CH_4 emissions (kg) over 20 years

BOD = Biochemical Oxygen Demand of influent (kg) over 20 years

Eff_{OD} = Oxygen demand removal efficiency, assumed 80%

CF_{CO_2} = Conversion factor for maximum CO_2 generation per unit of BOD
= 1.375 g CO_2 /g BOD

CF_{CH_4} = Conversion factor for maximum CH_4 generation per unit BOD
= 0.5 g CH_4 /g BOD

MCF_{ww} = Methane correction factor for wastewater treatment unit, indicating fraction of the influent oxygen demand that is converted anaerobically
= 0.8 for anaerobic, 0 for aerobic

BG_{CH_4} = Fraction of carbon as CH_4 in generated biogas (default is 0.65)

λ = Biomass yield (g C converted to biomass/g C consumed)
= 0.1 for anaerobic, 0.65 for aerobic

In the past decomposition within a pit of a pit latrine has been considered a strictly anaerobic process; however, one study identified during the literature review has shown that a significant portion of the organic content may decompose aerobically before it is covered and continues decomposing anaerobically (Bhagwan et al., 2008). This process is shown in Figure 11 which depicts the four different theoretical decomposition zones within the contents of the pit of a latrine. The ratio of aerobic to anaerobic decomposition taking place in the pit latrine is believed to depend on the moisture content of the material, the permeability of the surrounding soil, the level of the water table, flow of air through the pit, and addition of other materials to the pit (such as water for flushing, anal cleansing materials, or desiccants). The results of the

calculation in this study to determine the amount of methane and carbon dioxide emitted from a pit latrine are presented for two cases for the pit and pour-flush latrine: (1) completely anaerobic decomposition and (2) 50% aerobic, 50% anaerobic decomposition.

3.4.7 Resource Recovery through Biogas and Nutrients

3.4.7.1 Biogas

The biogas produced by the biodigester is calculated using Equations 8 and 9 from the EPA method (EPA, 2010). An 80% BOD removal efficiency has been reported as typical for the Taiwanese style digesters (Lansing et al., 2008). This value results in the production of 2,700 m³ of methane and 2,490 m³ of CO₂ over a 20-year period (or 259 m³ of biogas per year). When accounting for the difference in energy content (35.8 MJ/m³ for methane and 39 MJ/m³ for natural gas) (Rittmann and McCarty, 2001; McGraw-Hill, 1982), this yields an equivalent of 2,470 m³ of natural gas use avoided over the 20-year period. This value is then inputted to SimaPro as an avoided product in the use phase of the biodigester latrine.

Equations 8 and 9 were used to calculate the mass of carbon dioxide and methane produced by each sanitation system are provided in Table 10. These values were inputted to SimaPro as emissions to air in the use phase of each system.

Table 10: Biogenic emissions associated with each system.

	CO ₂ (kg)	CH ₄ (kg)
VIP latrine	1,400 ¹	510 ¹
	1,270 ²	255 ²
Pour-flush latrine	1,400 ¹	510 ¹
	1,270 ²	255 ²
Composting latrine	1,140	-
Biodigester latrine	4,460 ³	1,760 ³
	9,290 ⁴	-

¹ Assuming complete anaerobic degradation

² Assuming 50% anaerobic, 50% aerobic degradation

³ Assuming biogas is not captured, and is instead released directly to air

⁴ Assuming all biogas is captured and combusted

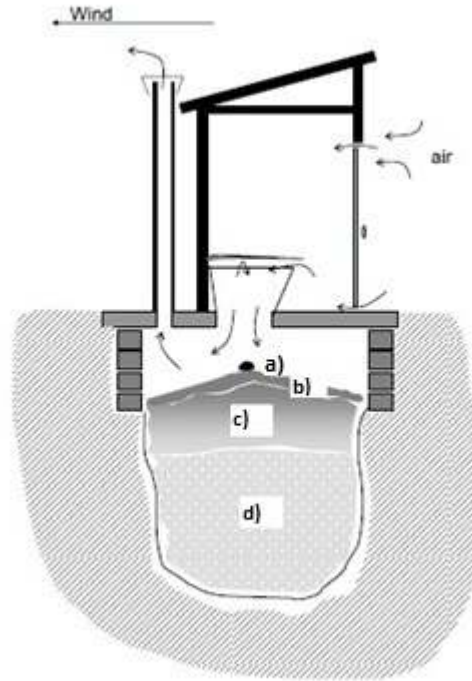

Figure 11: Diagram of VIP latrine showing different theoretical layers. (a) fresh stool; (b) partially degraded aerobic surface layer; (c) partially degraded anaerobic layer beneath surface; (d) completely stabilized anaerobic layer. Source: Buckley et al. (2008) with permission.

3.4.7.2 Biodigester Effluent

The fertilizer potential of the biodigester was determined based on the nitrogen content of the effluent. A 222 L/day flowrate of digestate would produce 16,200 m³ of effluent over a 20-year period. Table 3 provided the nutrient concentration found in potential biodigester feeds. The nitrogen content of the human waste was determined using the values from Table 2 (Esrey, 2000).

$$12.5 \frac{g N}{person \cdot day} * 5.05 \text{ people} * \frac{365 \text{ days}}{year} * 20 \text{ years} * \frac{1 kg}{10^3 g} = 461 \text{ kg N} \quad (10)$$

The nitrogen content of the manure slurry was determined using values from ASAE (2005). Typical cow manure slurry for household biodigesters consists of a 1:3 ratio of manure

to water. As mentioned in section 3.4.3 (Biochemical Oxygen Demand) 159 L of cow manure slurry are added daily to satisfy the operational requirements of the biodigester.

$$6620 \frac{mg\ N}{L} * \frac{1\ L\ manure}{4\ L\ slurry} * \frac{159\ L}{day} * \frac{365\ days}{year} * 20\ years * \frac{1\ kg}{10^6\ mg} = 1921\ kg\ N \quad (11)$$

The sum of the values from Equations 10 and 11 results in 2,382 kg N produced in the biodigester effluent over a 20-year period. This value was inputted to SimaPro as the mass of urea fertilizer (as N) use avoided. Other elements present in the effluent and compost, such as potassium and calcium, are not included in the resource recovery calculation because these elements are not the main components of fertilizers typically used in the study site.

3.4.7.3 Compost and Urine Diversion

According to the data provided previously in Table 2, one person produces 11 g of nitrogen in urine and 1.55 g of nitrogen in feces per day (Esrey, 2000; Jönsson et al., 2004). Nitrogen losses associated with urine diversion, collection, and use are assumed to be negligible because there is little opportunity for the volatilization of ammonia within a sealed receptacle. The feces are aerobically composted within the chambers of the composting latrine. A model for the loss of nitrogen during aerobic decomposition from Kirchman and Witter (1989) predicts a 34.3% loss of nitrogen through the volatilization of ammonia for compost with C:N ratio of 10 and 1-year storage time. This is within the 10-50% range suggested by Jönsson et al. (2004) for nitrogen loss during aerobic composting. Assuming 34.3% loss of nitrogen, a household composting latrine with urine diversion (and collection) would therefore produce 443 kg of nitrogen over a 20-year span. This value is inputted to SimaPro as urea fertilizer (as N) use avoided in the use phase of the composting latrine.

3.5 Sensitivity Analysis

A sensitivity analysis was performed to identify changes to which input parameters the results are more sensitive. The top five contributors in each system were considered. The value

for each input was modified by 20% and the CED and GWP of the system were calculated to determine how the change in the input impacted the resulting CED and GWP. The percent change in CED and GWP was then divided by the percent change of the input parameter to determine the sensitivity factor.

3.6 Life Cycle Impact Assessment and Interpretation

To perform the impact assessment and interpretation steps of the life cycle, the Cumulative Energy Demand (CED) and Global Warming Potential (GWP) methods in SimaPro 7.2 (PRé Consultants, 2008) were used to calculate the results. Embodied energy in terms of CED (MJ) was quantified using the CED method and carbon footprint in terms of GWP (kgCO₂ eq) was quantified using the Intergovernmental Panel on Climate Change (IPCC) 2007 GWP 100a method.

CHAPTER 4: RESULTS AND DISCUSSION

4.1 Impact of Privacy Structure on CED and GWP

The CED and GWP values of the construction phase of the four latrine designs and their variations are provided in this section. The materials used in construction of the privacy structure of the latrine can vary depending on location. This will change the latrine's environmental impact without affecting its function as a sanitation system. Many possibilities exist in constructing a privacy structure of a latrine due to material availability, cost, and regional/local preferences. In this study, two scenarios were chosen for comparison of the CED and GWP contributed by the privacy shelter: (1) adobe brick walls with a fiber cement roof and (2) brick walls with a corrugated metal roof. Table 11 provides a description of the design variations considered in this study. Complete material inventories for each latrine are provided in Appendix A. The CED and GWP for the construction phase, including the privacy structure and other construction aspects, of each latrine are provided in Figure 12.

Figures 12a and 12b show that the unlined VIP latrine has the lowest CED and GWP values at 760 MJ and 58.4 kgCO₂ eq, respectively. There is no brick used in this design for lining the pit or construction of the privacy structure and the CED is over 7.5 times less than the same latrine design with a brick lined pit. Excluding the unlined VIP latrine, the CED values of the other latrines vary between 5,724 MJ for the VIP latrine with adobe fiber cement privacy structure and 20,474 MJ for the biodigester latrine with brick corrugated metal privacy structure. Designs using brick as a construction material have an average CED of 5,445 MJ higher for the construction phase than those using adobe. The GWP values for each latrine vary between 502 kgCO₂ eq for VIP latrine with adobe fiber cement privacy structure to 1,724 kgCO₂ eq for the pour-flush latrine with brick corrugated metal privacy structure.

Table 11: Latrine design variations considered in this study.

Variation of latrine type and privacy shelter	Notes
VIP latrine adobe fiber cement	<ul style="list-style-type: none"> • Pit lined with brick • Adobe walls, fiber cement roof
VIP latrine adobe fiber cement (unlined pit)	<ul style="list-style-type: none"> • Pit unlined • Adobe walls, fiber cement roof
VIP latrine brick corrugated metal	<ul style="list-style-type: none"> • Pit lined with brick • Brick walls, corrugated metal roof
Pour-flush latrine adobe fiber cement	<ul style="list-style-type: none"> • Pit lined with brick • Adobe walls, fiber cement roof
Pour-flush latrine brick corrugated metal	<ul style="list-style-type: none"> • Pit lined with brick • Brick walls, corrugated metal roof
Composting latrine adobe fiber cement	<ul style="list-style-type: none"> • Chambers built from brick • Upper walls built from adobe, fiber cement roof
Composting latrine brick corrugated metal	<ul style="list-style-type: none"> • Chambers built from brick • Upper walls built from brick, corrugated metal roof
Biodigester latrine adobe fiber cement	<ul style="list-style-type: none"> • Trench reactor housing lined with adobe with concrete inlet and outlets • Superstructure built from adobe, fiber cement roof
Biodigester latrine brick corrugated metal	<ul style="list-style-type: none"> • Trench reactor housing lined with adobe with concrete inlet and outlets • Superstructure walls built from brick, corrugated metal roof

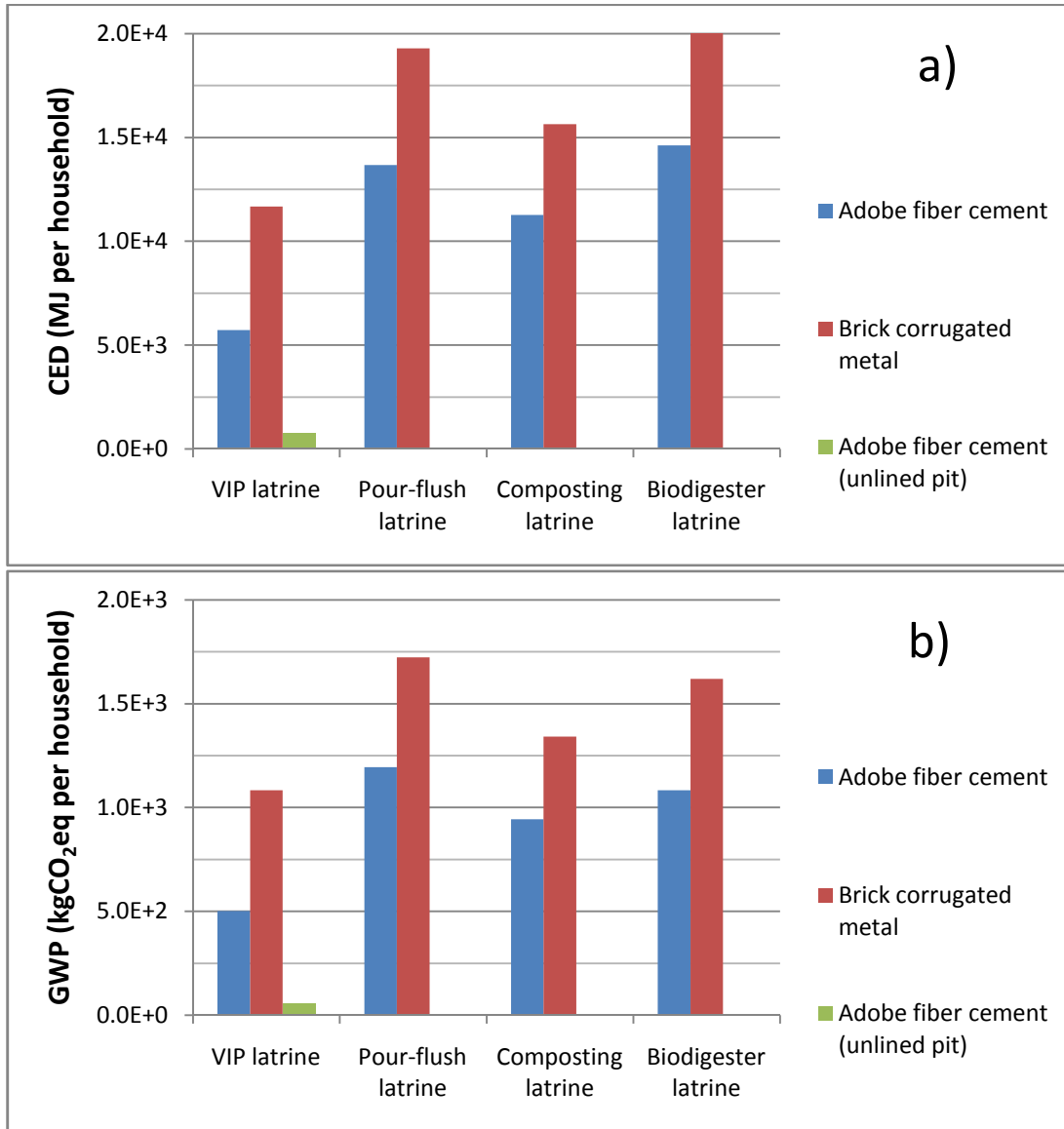

Figure 12: (a) Cumulative energy demand and (b) global warming potential of construction phase of sanitation systems.

Similarly, designs using brick have average GWP 512 kgCO₂ eq higher than those using adobe. The difference between the CED and GWP values for fiber cement and corrugated metal was negligible at (29 MJ and 7.3 kgCO₂ eq, respectively). The contributions to the overall CED and GWP for each latrine are provided in Tables 12 and 13. Complete LCA results can be found in Appendix B.

Table 12: Cumulative energy demand of latrine components for construction phase.

	VIP latrine adobe fiber cement	VIP latrine adobe fiber cement (unlined pit)	VIP latrine brick corrugated metal	Pour-flush latrine adobe fiber cement	Pour-flush latrine brick corrugated metal	Composting latrine adobe fiber cement	Composting latrine brick corrugated metal	Biodigester latrine adobe fiber cement	Biodigester latrine brick corrugated metal
Material	CED (MJ) (%)	CED (MJ) (%)	CED (MJ) (%)	CED (MJ) (%)	CED (MJ) (%)	CED (MJ) (%)	CED (MJ) (%)	CED (MJ) (%)	CED (MJ) (%)
Brick	4,020 (70.2)	-	8,614 (73.8)	4,020 (29.4)	8,614 (44.6)	3,446 (30.6)	6,891 (44.1)	1,723 (11.8)	6,317 (30.8)
Transport	751 (13.1)	130.7 (17.2)	1,589 (13.6)	3,788 (27.7)	4,407 (22.8)	2,483 (22.0)	3,046 (19.5)	2,929 (20.0)	3,716 (18.1)
Portland cement	404 (7.1)	80.7 (10.6)	888 (7.6)	2,018 (14.8)	2,502 (13.0)	1,453 (12.7)	1,776 (11.4)	2,066 (14.1)	2,550 (12.4)
Fiber cement	268 (4.7)	268 (35.2)	-	268 (2.0)	-	268 (2.4)	-	268 (1.8)	-
Corrugated metal	-	-	297 (2.5)	-	297 (1.5)	-	297 (1.9)	-	297 (1.5)
Sanitary ceramics	-	-	-	1,942 (14.2)	1,942 (10.1)	1,349 (12.0)	1,349 (8.6)	1,942 (13.3)	1,942 (9.5)
PVC pipe	92 (1.6)	92 (12.2)	92 (0.8)	524 (3.8)	524 (2.7)	644 (5.7)	644 (4.1)	861 (5.9)	861 (4.2)
PVC geomembrane	-	-	-	-	-	-	-	2,665 (18.2)	2,665 (13.0)
Other	189 (3.3)	189 (24.9)	189 (1.6)	1,108 (8.1)	1,010 (5.2)	1,633 (14.5)	1,633 (10.4)	2,175 (14.9)	2,139 (10.4)
Total	5,724 (100)	760 (100)	11,668 (100)	13,667 (100)	19,295 (100)	11,275 (100)	15,636 (100)	14,628 (100)	20,474 (100)

Table 13: Global warming potential of latrine components for construction phase.

	VIP latrine adobe and fiber cement	VIP latrine adobe fiber cement (unlined pit)	VIP latrine brick corrugated metal	Pour-flush latrine adobe fiber cement	Pour-flush latrine brick corrugated metal	Composting latrine adobe fiber cement	Composting latrine brick corrugated metal	Biodigester latrine adobe fiber cement	Biodigester latrine brick corrugated metal
Material	GWP (kgCO ₂ eq) (%)	GWP (kgCO ₂ eq) (%)	GWP (kgCO ₂ eq) (%)	GWP (kgCO ₂ eq) (%)	GWP (kgCO ₂ eq) (%)	GWP (kgCO ₂ eq) (%)	GWP (kgCO ₂ eq) (%)	GWP (kgCO ₂ eq) (%)	GWP (kgCO ₂ eq) (%)
Brick	338 (67.3)	-	724 (66.8)	338 (28.3)	724 (42.0)	290 (30.7)	579 (43.2)	145 (13.4)	531 (33.2)
Transport	43.2 (8.6)	7.5 (12.9)	127 (11.7)	218 (18.2)	253 (14.7)	143 (15.1)	175 (13.0)	211 (16.6)	214 (13.3)
Portland cement	87.3 (17.4)	17.5 (29.9)	192 (17.7)	436 (36.5)	541 (31.4)	314 (33.3)	384 (28.6)	447 (41.2)	551 (34.5)
Fiber cement	19.9 (4.0)	19.9 (34.1)	-	19.9 (1.7)	-	19.9 (2.1)	-	19.9 (1.8)	-
Corrugated metal	-	-	27.2 (2.5)	-	27.2 (1.6)	-	27.2 (2.0)	-	27.2 (1.7)
Sanitary ceramics	-	-	-	106 (8.9)	106 (6.1)	73.5 (7.8)	73.5 (5.5)	106 (9.8)	106 (6.6)
PVC pipe	4.4 (0.9)	4.4 (7.5)	4.4 (0.4)	24.9 (2.1)	24.9 (1.4)	30.6 (3.2)	30.6 (2.3)	41.0 (3.8)	41.0 (2.6)
PVC geomembrane	-	-	-	-	-	-	-	87.3 (8.1)	87.3 (5.4)
Other	9.1 (1.8)	9.1 (15.7)	9.1 (0.8)	51.5 (4.3)	47.8 (2.8)	72.7 (7.7)	72.7 (5.4)	69.9 (6.4)	63.1 (3.9)
Total	502 (100)	58.4 (100)	1,084 (100)	1,194 (100)	1,724 (100)	943 (100)	1,342 (100)	1,084 (100)	1,620 (100)

In general, the main contributors to the CED and GWP of the construction phase of each latrine are brick, transport, and cement which on average account for 41.9%, 19.3%, and 11.5% of the CED and 40.6%, 13.8%, and 30.1% of the GWP, respectively.

4.2 CED and GWP Associated with Use Phase and Resource Recovery

In this section the CED and GWP of the construction and use phases of each latrine over a 20-year period are examined. Different use phase scenarios are considered and the adobe and fiber cement privacy structure is considered for the construction phase. Figure 13 provides the CED values with and without resource recovery of each sanitation system.

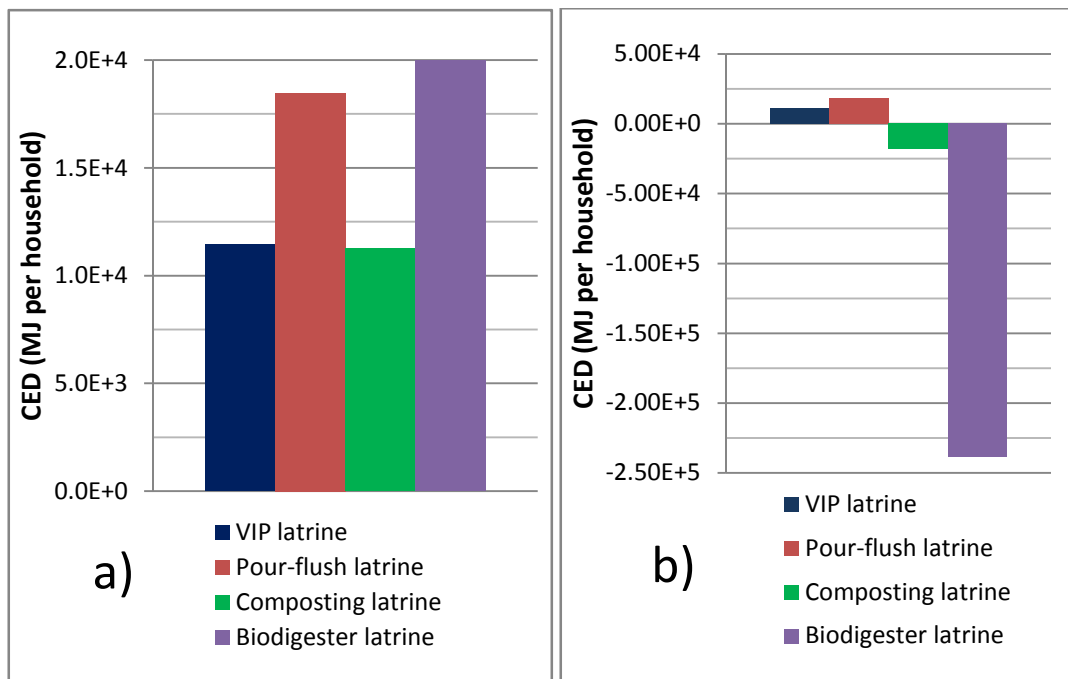

Figure 13: Cumulative energy demand of four sanitation systems over a 20-year period (a) without resource recovery and (b) with resource recovery. Note: VIP and pour-flush latrine do not recover resources and their CED values are repeated for comparison. Resource recovery of the biodigester latrine is based on the combined input from the household latrine and cow manure slurry.

The VIP and pour-flush latrine do not feature resource recovery and, therefore the same value is presented in Figure 13a and 13b with and without resource recovery (11,447 MJ and 18,464 MJ, respectively). Resources are recovered in the composting latrine and biodigester

latrine through use of the compost and effluent as soil amendments (and fertilizers) and in the case of the biodigester latrine, through use of the biogas as fuel source for cooking. These values are quantified in terms of the avoided products associated with them, i.e., the nitrogen fertilizer (urea) and natural gas use avoided. These resource recovery scenarios are considered ideal; that is, all of the nitrogen found in the compost, diverted urine, and biodigester effluent is directly replacing and equivalent amount of commercial nitrogen fertilizer. Thus the results are presented for the maximum use avoided. These results along with the other contributors to the overall CED values for each latrine are provided in Table 14.

Table 14: Contributions to cumulative energy demand of four sanitation systems that consider resource recovery over 20-year life.

	VIP latrine	Pour-flush latrine	Composting latrine without resource recovery	Composting latrine with resource recovery	Biodigester latrine without resource recovery	Biodigester latrine with resource recovery
	CED (MJ)	CED (MJ)	CED (MJ)	CED (MJ)	CED (MJ)	CED (MJ)
Construction phase	5,724	13,667	11,275	11,275	14,628	14,628
Use phase (maintenance)	5,724	4,798	-	-	5,362	5,362
Fertilizer use avoided (N)	-	-	-	-29,333	-	-157,865
Natural gas use avoided	-	-	-	-	-	-95,325
Total	11,447	18,464	11,275	-18,058	19,990	-233,200

In Table 14, the CED values of the systems without resource recovery range between 11,275 MJ and 19,990 MJ. However, when resource recovery is considered, as shown in Figure 13b and Table 14, the composting and biodigester latrines become net energy producers over the 20-year period. In fact, the biodigester latrine recovers over 12 times the amount of energy than it requires for construction and maintenance. The large values for resource recovery for the

biodigester latrine are due to combined BOD input to the system from the household latrine and the cow manure slurry. This total combined input was calculated as 3.2 times the input from only a household latrine in terms of BOD content. The fertilizer use avoided of the biogas accounts for 62.4% of the overall resource recovery potential of the biodigester latrine while the natural gas use avoided of the biogas accounts for 37.6%.

Like the CED, the GWP of each system is based on the material inputs from the construction, maintenance, avoided products due to resource recovery, but also includes the contribution from biogenic emissions. As shown in section 3.4.6 (Biogenic Emissions), the results are presented for the degradation of the waste within the pit of the VIP and pour-flush latrines as either 100% anaerobic or 50% aerobic/50% anaerobic. 100% aerobic degradation is assumed to take place within the composting latrine. Three scenarios are considered for the use phase of the biodigester latrine which affect its biogenic emissions and avoided products: (1) the system is operated without resource recovery, i.e., the biogas is not captured, and instead is released directly to the air and the effluent is not used as fertilizer, (2) the system is operated without resource recovery; however, the biogas is captured and combusted, but not used for cooking (i.e., flared or burned in biogas lamp), and (3) the system is operated with resource recovery, i.e., the biogas is captured and used for cooking and the effluent is used as fertilizer, replacing commercial fertilizer. Figure 14 provides the GWP of each latrine with and without resource recovery.

Again, the VIP and pour-flush latrine are not designed to recover resources and their GWP values are reproduced in Figure 14b for comparison. In general, the biogenic emissions, specifically methane which is 25 times more powerful than carbon dioxide as a greenhouse gas, dominate the overall GWP of each latrine. When anaerobic degradation takes place, the sludge is converted to methane and carbon dioxide, whereas aerobic degradation produces only carbon dioxide. The GWP of the biodigester latrine operated without resource recovery is over 3

times higher than the next highest system. This is because not only human waste, but also cow manure is contributing to the biogenic emissions.

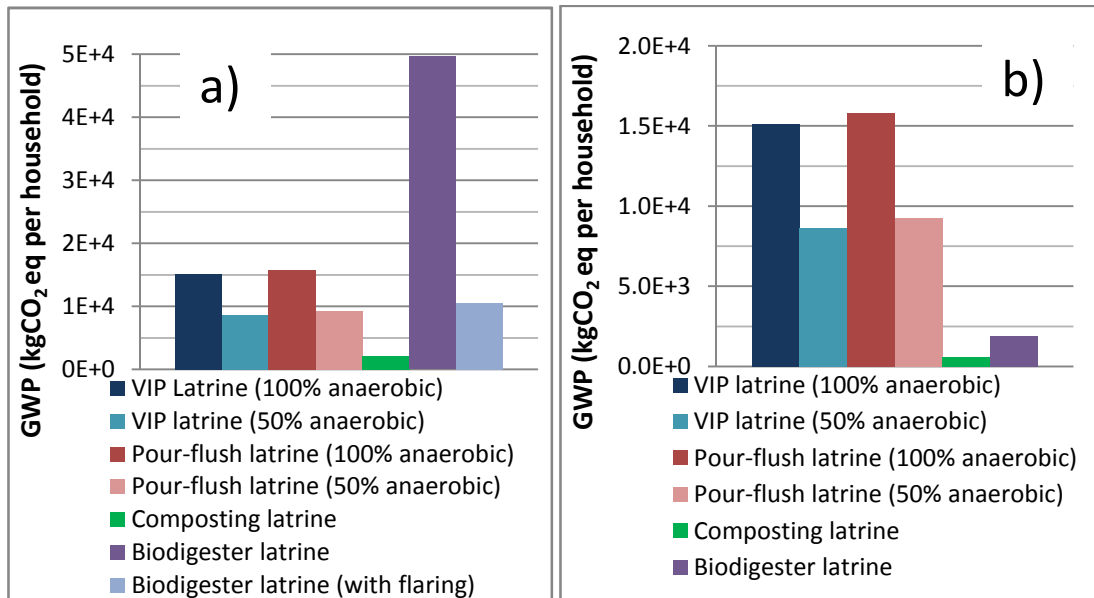

Figure 14: Global warming potential of four sanitation systems over a 20-year period (a) without resource recovery and (b) with resource recovery. Biogenic emissions and resource recovery of the biodigester latrine is based on the combined input from the household latrine and cow manure slurry.

When operated with resource recovery, household sanitation systems have relatively small carbon footprint compared to systems without resource recovery. For example, the GWP of the composting latrine is reduced from 2,079 kgCO₂ eq to 616 kgCO₂ eq when resource recovery is considered. In the case of the biodigester the GWP is reduced from 49,655 kgCO₂ eq without resource recovery to 10,562 kgCO₂ eq if the biogas is simply flared or 1,882 kgCO₂ eq with resource recovery. The contributions to the overall GWP of each latrine is provided in Table 15.

Table 15: Contributions to global warming potential of sanitation systems over 20-year life.

	VIP latrine ¹	VIP latrine ²	Pour-flush latrine ¹	Pour-flush latrine ²	Composting latrine without resource recovery	Composting latrine with resource recovery	Biodigester latrine without resource recovery ³	Biodigester latrine with resource recovery ⁴	Biodigester latrine without resource recovery with flaring ⁴
	GWP (kgCO ₂ eq) (%)	GWP (kgCO ₂ eq) (%)	GWP (kgCO ₂ eq) (%)	GWP (kgCO ₂ eq) (%)	GWP (kgCO ₂ eq) (%)	GWP (kgCO ₂ eq)	GWP (kgCO ₂ eq) (%)	GWP (kgCO ₂ eq)	GWP (kgCO ₂ eq) (%)
Construction phase	502 (3.3)	502 (3.3)	1,211 (7.7)	1,211 (12.9)	943 (45.4)	943	1,084 (2.2)	1,084	1,084 (10.3)
Use phase (maintenance)	502 (3.3)	502 (3.3)	453 (2.9)	453 (4.8)			186 (0.4)	186	186 (1.8)
Direct CH ₄	12,741 (84.1)	6,370 (73.7)	12,741 (80.7)	6,370 (67.9)	-	-	43,926 (88.5)	-	-
Direct CO ₂	1,401 (9.2)	1,268 (14.7)	1,401 (8.9)	1,268 (13.5)	1,135 (54.6)	1,135	4,460 (9.0)	9,293	9,293 (88.0)
Fertilizer use avoided (N)	-	-	-	-	-	-1,462	-	-7,869	-
Natural gas use avoided	-	-	-	-	-	-	-	-811	-
Total	15,146 (100)	8,642 (100)	15,789 (100)	9,286 (100)	2,079 (100)	616	49,655 (100)	1,882	10,562 (100)

¹Assuming complete anaerobic degradation

²Assuming 50% anaerobic, 50% aerobic degradation

³Assuming biogas is not captured, and is instead released directly to air

⁴Assuming all biogas is captured and combusted

In general, the biogenic emissions dominate the overall GWP of each latrine. The contribution of biogenic emissions to the GWP is lowest for the composting latrine at 1,135 kgCO₂ eq, or 54.6% of the overall GWP. This is due to the strictly aerobic biochemical process taking place within the composting latrine which produces only carbon dioxide. The contributions of biogenic emissions, maintenance and construction to the overall GWP of each latrine are also presented in Figure 15. An 80% BOD removal efficiency was assumed for each of the systems; however, one study done on thermophilic composting of swine wasting measured only a 30% reduction of the total organic carbon due to thermophilic composting of swine waste (Zhu, 2007). Using a 30% BOD removal efficiency, the biogenic CO₂ emissions of the composting latrine would be 426 kgCO₂ eq compared to 1,135 kgCO₂ eq with an 80% efficiency.

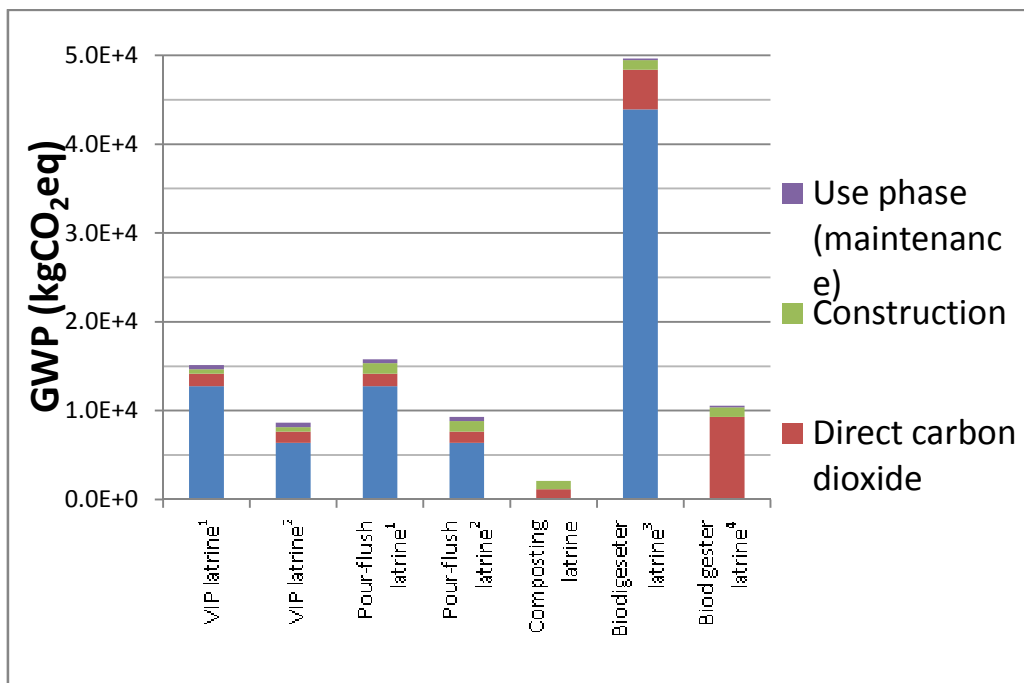

Figure 15: Contribution of materials and biogenic emissions to global warming potential for each sanitation system.

¹Assuming complete anaerobic degradation

²Assuming 50% anaerobic, 50% aerobic degradation

³Assuming biogas is not captured, and is instead released directly to air

⁴Assuming all biogas is captured and combusted

4.3 CED and GWP of Household and Community-Level Sanitation Systems

The CED and GWP of two community wastewater treatment systems in rural Bolivia were studied by Cornejo et al. (2013). The community system of Sapecho serves a sewerred community of 1,039 people (206 households) and includes a grit chamber, upflow anaerobic sludge blanket (UASB) reactor and two maturation lagoons. The community system of San Antonio serves a sewerred community of 420 people (150 households) and includes a three-pond system (one facultative and two maturation lagoons). Both systems are currently operated without resource recovery, but the calculations made by Cornejo et al. (2013) are based on potential use phases implementing resource recovery. In the case the community system of Sapecho, resource recovery is associated with the recovery of biogas produced by the UASB reactor and reuse of the system's effluent for irrigation. For the community system of San Antonio resource recovery is only associated with reuse of the system's effluent for irrigation. The results from this study on community systems in terms of CED are provided in Figure 16 along with the results for household systems discussed in the previous section that are presented for comparison.

Figure 16a shows that the average CED per household of the community systems without resource recovery (41,738 MJ) is 2.7 times more than the average CED of the household systems without resource recovery (15,294 MJ). This is because of the higher material inputs of the infrastructure of the community collection system. For example, in this location the collection system alone accounts for 41% and 49% of the overall CED of community systems of Sapecho and San Antonio, respectively.

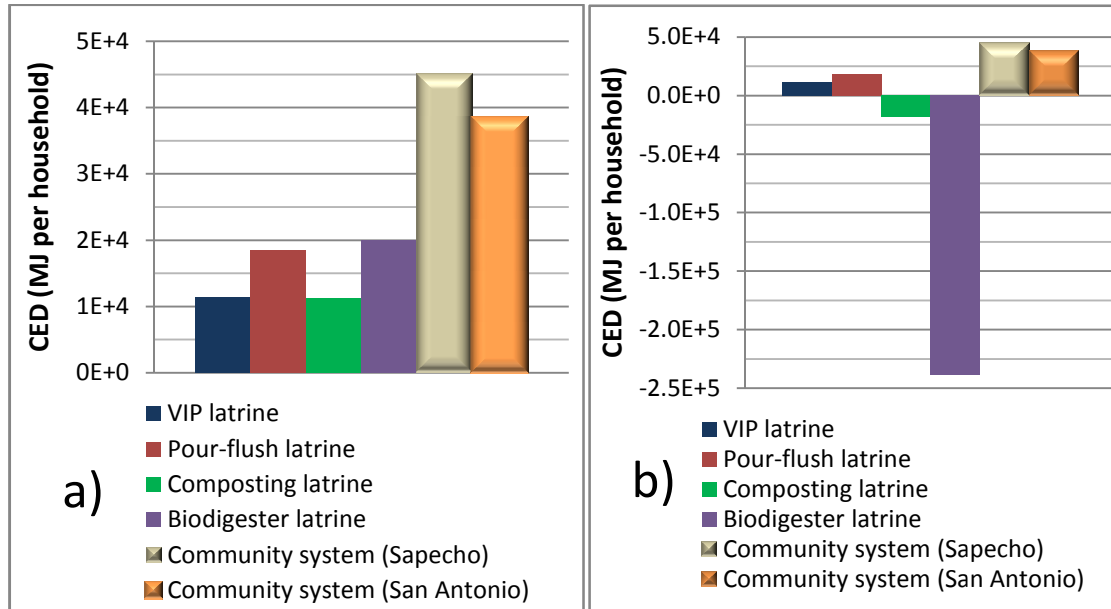

Figure 16: Cumulative energy demand of household and community level sanitation systems per household over 20-year period (a) without resource recovery and (b) with resource recovery.

Resource recovery was interpreted slightly differently for the household and community systems which may lead to different contributions to the CED and GWP for each system in the resource recovery condition. For example, the biogas for the household system is considered in terms of an equivalent mass (based on energy content) of natural gas use avoided while in the case of the community system of Sapecho biogas itself is considered a co-product of the system. Likewise, the effluent and compost of the household systems are modeled in terms of the avoided use of urea fertilizer with an equivalent mass of nitrogen while in the community systems the use of the system effluent is indirectly quantified in terms of the river water use for irrigation avoided and crop yield increases. This was done because commercial nitrogen fertilizer is not commonly used in agriculture in the Bolivian study site. It is thus likely that the resource recovery potential for the use of the effluent in the community systems is underestimated compared to the resource recovery potential of the use of the compost and household biodigester effluent. Figure 16b shows that the CED per household of the community systems with resource recovery are 44,869 MJ for Sapecho and 38,403 MJ for San Antonio.

Figure 17 provides the global warming potential of household and community level sanitation systems per household over 20-years.

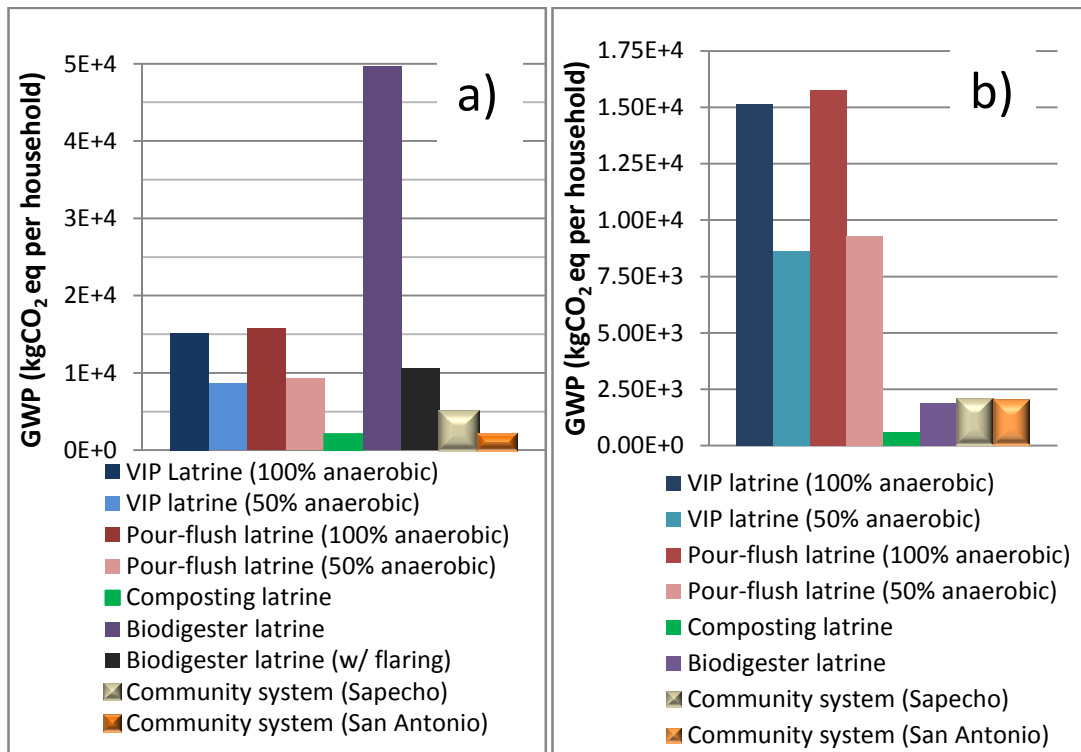

Figure 17: Global warming potential of household and community level sanitation systems per household over 20-year period (a) without resource recovery and (b) with resource recovery.

Similar to the case of household latrines, the results in Figure 17 are influenced by biogenic emissions that are the main contributors to the overall GWP of the community systems. Biogenic emissions account for 67% of the overall GWP of the Sapecho system without resource recovery and 53% of the overall GWP of San Antonio system. Implementation of combined resource recovery in the Sapecho system (recovery of biogas and irrigation with system effluent) was estimated to reduce the overall GWP from 4,930 kgCO₂ eq to 2,092 kgCO₂ eq, or 58.4%. In the case of the San Antonio system, implementation of resource recovery (irrigation with system effluent) was estimated to reduce the overall GWP from 2,022 kgCO₂ eq to 2,019 kgCO₂ eq., or 0.1%. The community systems have a lower GWP per household than the conventional household latrines that do not recover resources, i.e., VIP and pour-flush

latrine, but have a slightly higher GWP than household systems that incorporate resource recovery. Similarly, a study by Fuchs and Mihelcic (2011) in the same study site in Bolivia as Cornejo et al. (2013) determined that decentralized or semi-decentralized sanitation systems, such as condominial sewer systems, most closely satisfied the appropriate technology characteristics measured.

The BOD input was calculated slightly differently for the household and community systems. As mentioned in section 3.4.3 (Biochemical Oxygen Demand Input), the BOD input value for the household systems is based on the value of BOD production rate per capita of 80 g BOD/person-day typically used in the wastewater design literature (Metcalf and Eddy, 2003). For the community treatment systems, the BOD input was based on actual field measurements of the influent wastewater. These values, when converted to a BOD production rate per capita result in a value of only 16 g BOD/person-day for the Sapecho system and 27 g/person-day for the San Antonio system. These values are 3-5 times lower than the literature value for conventional wastewater treatment design likely due to the fact that the wastewater does not include food waste and that it is a largely agricultural area where people may not have access to residential bathrooms during the work day. This leads to subsequently lower values for the biogenic emissions and biogas production for the community systems compared to the household systems.

4.4 Sensitivity Analysis

Sensitivity factors (SFs) for the privacy structure results are provided in Table 16 and for the use phase and resource recovery results in Table 17. Larger sensitivity factors indicate greater sensitivity in the results to changes in input values and vice versa.

For both the privacy structure and use phase results, the most sensitive items in terms of embodied energy include: brick, transport, cement, and the PVC geomembrane, in the case of the biodigester latrine. Their high contribution of these input parameters to the total embodied

energy (27-95%) may be the reason they are more sensitive. Individual contributions to CED are provided in Appendix B. Future studies can refine these input values to improve the accuracy of the model.

When considering only the privacy structure results, the most sensitive items in terms of carbon footprint are similar to those of embodied energy: brick, transport, and cement, which account for between 42-96% of the total GWP. However, when considering the use phase, the most sensitive items are the biogenic emissions of methane and carbon dioxide, which account for between 50-97% of the GWP, followed by brick, transport, and cement. Future research refining the calculation in terms of the actual biogenic emissions associated with each system, and to a lesser extent material inputs, would improve the accuracy of the model.

It is possible that in the study site the biogas, when used for cooking, would actually replace propane rather than natural gas. The energy ladder that is commonly used to explain how households advance to cleaner and more expensive forms of energy from solid fuels considers propane and natural gas usage at a similar level of development (Smith et al., 1994). However, if one considers the resource recovery potential of the biogas as propane use avoided rather than natural gas use avoided affects the results for CED and GWP. The overall CED for the biodigester latrine using propane use avoided for the biogas is 8.8% higher (- 212,700 MJ) than in terms of natural gas use avoided (- 233,200 MJ). The GWP for the biodigester latrine is 7.7% lower with the biogas considered in terms of propane use avoided (1,740 kgCO₂ eq) than when considered as natural gas use avoided (1,880 kgCO₂ eq).

Table 16: Sensitivity factors for privacy shelter (construction phase) results.

Variation of latrine type and privacy shelter	Input	SF of CED	SF of GWP
VIP latrine adobe fiber cement	Brick	0.703	0.673
	Transport	0.131	0.085
	Cement	0.070	0.174
	Fiber cement	0.048	0.040
	PVC pipe	0.013	0.010
VIP latrine adobe fiber cement (unlined pit)	Fiber cement	0.352	0.337
	Transport	0.174	0.128
	PVC pipe	0.122	0.085
	Cement	0.108	0.299
	Plywood	0.069	0.017
VIP latrine brick corrugated metal	Brick	0.738	0.690
	Transport	0.137	0.088
	Cement	0.076	0.183
	Corrugated metal	0.026	0.026
	PVC pipe	0.008	0.004
Pour-flush latrine adobe fiber cement	Brick	0.294	0.283
	Transport	0.277	0.182
	Cement	0.148	0.365
	Sanitary ceramics	0.142	0.089
	PVC pipe	0.039	0.021
Pour-flush latrine brick corrugated metal	Brick	0.442	0.420
	Transport	0.226	0.147
	Cement	0.128	0.314
	Sanitary ceramics	0.100	0.061
	PVC pipe	0.027	0.015
Composting latrine adobe fiber cement	Brick	0.306	0.307
	Transport	0.220	0.151
	Cement	0.129	0.333
	Sanitary ceramics	0.120	0.078
	PVC pipe	0.057	0.032
Composting latrine brick corrugated metal	Brick	0.441	0.432
	Transport	0.195	0.130
	Cement	0.114	0.286
	Sanitary ceramics	0.087	0.055
	PVC pipe	0.041	0.023
Biodigester latrine adobe fiber cement	Transport	0.204	0.157
	Geomembrane PVC	0.186	0.082
	Cement	0.144	0.417
	Sanitary ceramics	0.136	0.099
	Brick	0.120	0.135
Biodigester latrine brick corrugated metal	Brick	0.309	0.328
	Transport	0.182	0.132
	Geomembrane PVC	0.130	0.054
	Cement	0.125	0.340
	Sanitary ceramics	0.095	0.065

Table 17: Sensitivity factors for construction and use phase results.

Latrine type and use phase	Input	SF of CED	SF of GWP
VIP latrine adobe fiber cement (100% anaerobic)	Biogenic CH ₄	-	0.841
	Biogenic CO ₂	-	0.093
	Brick	0.704	0.045
	Transport	0.132	0.006
	Cement	0.071	0.012
VIP latrine adobe fiber cement (50% anaerobic, 50% aerobic)	Biogenic CH ₄	-	0.841
	Biogenic CO ₂	-	0.093
	Brick	0.704	0.045
	Transport	0.132	0.006
	Cement	0.071	0.012
Pour-flush latrine adobe fiber cement (100% anaerobic)	Biogenic CH ₄	-	0.803
	Biogenic CO ₂	-	0.088
	Brick	0.439	0.043
	Transport	0.175	0.012
	Cement	0.158	0.040
Pour-flush latrine adobe fiber cement (50% anaerobic, 50% aerobic)	Biogenic CH ₄	-	0.688
	Biogenic CO ₂	-	0.137
	Brick	0.451	0.073
	Transport	0.179	0.020
	Cement	0.163	0.057
Composting latrine adobe fiber cement without resource recovery	Biogenic CO ₂	-	0.546
	Brick	0.306	0.139
	Transport	0.220	0.069
	Cement	0.129	0.151
	Sanitary ceramics	0.120	0.035
Biodigester latrine adobe fiber cement without resource recovery	Biogenic CH ₄	-	0.885
	Biogenic CO ₂	-	0.090
	Geomembrane PVC	0.387	0.005
	Transport	0.118	0.003
	Cement	0.105	0.009
Biodigester latrine adobe fiber cement without resource recovery with flaring	Biogenic CO ₂	-	0.880
	Geomembrane PVC	0.387	0.024
	Transport	0.169	0.018
	Cement	0.105	0.042
	Sanitary ceramics	0.099	0.010

CHAPTER 5: CONCLUSIONS AND RECOMMENDATIONS FOR FUTURE RESEARCH

The original hypothesis proposed in this thesis that sanitation systems that incorporate resource recovery will have higher CED than systems that do not recover resources due to additional material requirements during installation and maintenance, but will have lower GWP over their service life than those that do not. The first point of this hypothesis implies that additional material inputs are required to allow for resource recovery. Based on the results of this study, this is not correct. When only the construction phase is considered there is no correlation between the CED values of sanitation systems that incorporate resource recovery and those that do not. The VIP latrine had the lowest CED (5,724 MJ), followed by the composting latrine (11,275 MJ), the pour-flush latrine (13,667 MJ), and the biodigester latrine (14,628 MJ). However, when the use phase is considered the energy recovered through resource recovery more than offsets the energy required for construction and maintenance of both the composting and biodigester latrine. The composting latrine requires 11,275 MJ for construction and maintenance and recovers 29,933 MJ through use of the compost as a fertilizer substitute. The biodigester latrine requires 19,990 MJ for construction and maintenance and recovers 253,190 MJ through use of the effluent as a fertilizer substitute and the biogas as a substitute for natural gas for cooking. Therefore, both the composting and biodigester latrine are net energy producers over a 20-year period. Although they are not carbon neutral, their GWP of the systems incorporating resource recovery is considerably lower than the GWP of systems that do not. For example, the composting latrine has a GWP of 616 kgCO₂ eq and the biodigester latrine has a GWP of 1,882 kgCO₂ eq compared to 15,146 kgCO₂ eq and 15,789 kgCO₂ eq for the VIP latrine and pour-flush latrine, respectively.

The second hypothesis proposed in this thesis was that community systems that incorporate a collection system have a higher CED than household systems due to the material input requirements associated with the infrastructure of the system. Based on the results of this study this hypothesis is true. The CED values of the community systems of Sapecho (44,869 MJ per household) and San Antonio (38,403 MJ per household) with resource recovery were higher than the CED of any household sanitation systems with or without resource recovery (which ranged between 11,275 and 19,990 MJ). This result is because of the contribution of the collection system to the (which accounts for an average of 18,600 MJ per household) to the overall CED of the community systems. Interestingly, the GWP of community systems (2,019-2,092 kgCO₂ eq) is less than the GWP of household systems that do not incorporate resource recovery (8,642-15,789 kgCO₂ eq) and slightly more than household systems that recover resources (616-1,882 kgCO₂ eq).

As expected, the use of local materials in the construction of the privacy structure improves the environmental sustainability of the systems. Adobe brick is prepared manually at the construction site and dried in the sun while brick that is produced off-site in an industrial process has large energy input requirements. Design variations and material use have a large impact on the results in terms of CED. The main contributor to the GWP over the lifetime of these systems is the biogenic emissions, specifically for those that produce methane.

There is little data available about the actual biochemical processes taking place with the pit of a VIP or pour-flush latrine. Recent research suggests a combination of aerobic and anaerobic decomposition takes place within the pit; however, future research could more precisely determine the ratio of these processes occurring in the pit to allow for more accurate calculation of the associated biogenic emissions over the life of the latrine.

In addition, the service life of the Taiwanese tubular biodigester in the field can vary depending on maintenance and protection of the geomembrane from mechanical failure. Improperly operated or maintained biodigesters can produce significantly higher greenhouse

gas emissions due to biogas leaks. Future studies can more precisely determine this technology's service life and when applied in rural areas of developing countries and allow for more accurate description its potential to mitigate the effects of climate change.

REFERENCES

- American Society of Agricultural Engineers (ASAE). (2005). *Manure Production and Characteristics*. St. Joseph, MI.
- Bhagwan, J., Still, D., Buckley, C., and Foxon, K. (2008). Challenges with up-scaling dry sanitation technologies. *Water Science and Technology*, 58 (1), 21-27.
- Buckley, C., Foxon, K., Brouckaert, C., Rodda, N., Nwaneri, C., Balboni, E., Couderc, A., and Magagna, D. (2008). Scientific Support for the Design and Operation of Ventilated Improved Pit Latrines (VIPs) and the Efficacy of Pit Latrine Additives. South Africa: Water Research Commission.
- Botero Botero, R. and Preston, T. (1987). *Biodigestor de bajo costo para la produccion de biogas y fertilizante a partir de excretas*. Retrieved January 28, 2013, from: <http://www.produccion-animal.com.ar/Biodigestores/04-biodigestores.pdf>.
- Buyzman, E. (2009). *Anaerobic Digestion for Developing Countries with Cold Climates - Utilizing solar heat to address technical challenges and facilitating dissemination through the use of carbon finance*. Master's Thesis. University of Wagenigen. Retrieved April 23, 2012, from <https://wecf.eu/>.
- Cairncross, S. and Feachem, R. (1993). *Environmental Health Engineering in the Tropics: An Introductory Text*. Second Edition, Wiley and Sons, Chichester.
- Centers for Disease Control and Prevention (CDC). (2012). Global Water Sanitation and Hygiene 1600 Clifton Rd. Atlanta, GA 30333, USA. Retrieved January, 2013 from <http://www.cdc.gov/healthywater/global/index.html>.
- Chen, Y., Yang, G., Sweeney, S., and Feng, Y. (2010). Household biogas use in rural China: A study of opportunities and constraints. *Renewable and Sustainable Energy Reviews*, 14 (1), 545-549.
- City of Tampa. (2012). Advanced Wastewater Treatment Plant. Retrieved January 16, 2013 from http://www.tampagov.net/dept_wastewater/.
- Clasen, T. F. and Bastable, A. (2003). Faecal contamination of drinking water during collection and household storage: the need to extend protection to the point of use. *Journal of Water and Health*, 1 (3), 109-115.
- Clasen, T., Schmidt, W., Rabie, T., Roberts, I., and Cairncross, S. (2007). *Interventions to improve water quality for preventing diarrhoea: systematic review and meta-analysis*. BMJ. Retrieved January 22, 2013, from: <http://www.bmj.com/content/334/7597/782>.

- Cornejo, P., Zhang, Q., and Mihelcic, J.R. (2013). Embodied Energy and Carbon Footprint of Wastewater Treatment and Resource Recovery Strategies in a Developing World Setting. Unpublished.
- Côté, C., Massé, I., and Quessy, S. (2006). Reduction of indicator and pathogenic microorganisms by psychrophilic anaerobic digestion in swine slurries. *Bioresource Technology*, 97 (4), 686-691.
- EPA. (2006a). Life Cycle Assessment: Principles and Practice. EPA 600-R-06-060. Cincinnati.
- EPA. (2006b). Wastewater Management Fact Sheet-heat Drying. EPA 832-F-06-024. Retrieved January 25, 2013 from: http://water.epa.gov/scitech/wastetech/upload/2006_10_16_mtb_heat-drying.pdf.
- EPA. (2010). Greenhouse Gas Emissions Estimation Methodologies for Biogenic Emissions from Selected Source Categories. Draft. Washington, D.C.
- Esrey, S. (2000). Towards a recycling society: ecological sanitation - closing the loop to food security. *UNICEF Ecological Sanitation Symposium*. New York, NY.
- FAO. (2005). *Fertilizer use by crop in Ghana*. Retrieved January 29, 2013, from: <http://www.fao.org/docrep/008/a0013e/a0013e08.htm>
- FAO. (2011). The State of Food Insecurity in the World 2011.1-50. Rome.
- Fry, L.M., Cowden, J.R., Watkins, D.W., Clasen, T., and Mihelcic, J.R. (2010). Quantifying Health Improvements from Water Quantity Enhancement: An Engineering Perspective Applied to Rainwater Harvesting in West Africa. *Environmental Science & Technology*, 44 (24), 9535–9541.
- Fuchs, V.J. and Mihelcic, J.R. (2011). Analyzing appropriateness in sanitation projects in the Alto Beni region of Bolivia, *Waterlines*, 30 (2), 122-134.
- GTZ. (1999). Biogas Digest volume 1 Biogas Basics.1-45.
- GTZ. (1999). Biogas Digest Volume II Biogas - Application and Product Development.
- Guest, J.S., Skerlos S.J., Barnard J.L., Beck M.B., Daigger G.T., Hilger H., Jackson S.J., Karvazy K., Kelly L., Macpherson L., Mihelcic J.R., Pramanik A., Raskin L., van Loosdrecht M.C.M., Yeh D.H., and Love N.G. (2009). A New Planning and Design Paradigm to Achieve Sustainable Resource Recovery from Wastewater. *Environmental Science & Technology*, 43 (16), 6126–6130.
- Gunnerson, C.G. and Stuckey, D.C. (1986). Anaerobic Digestion- Principles and Practices for Biogas systems. Washington DC, World Bank & UNDP: 178.
- Heinonen-Tanski, H. and van Wijk-Sijbesma, C. (2005). Human excreta for plant production. *Bioresource Technology*, 96 (4), 403-411.

- Held, R.B., Zhang, Q., and Mihelcic, J.R. (2012). Quantification of human and embodied energy of improved water provided by source and household interventions. *Journal of Cleaner Production*, doi:10.1016/j.jclepro.2012.01.018.
- Hurtado, D. (2005). *Compost Latrines in Rural Panama: Design, Construction and Evaluation of Pathogen Removal*. Michigan Technological University, Houghton, MI. Retrieved January 17, 2013, from: <http://usfmi.weebly.com/thesesreports.html>.
- Intergovernmental Panel on Climate Change. (2007). *Fourth Assessment Report: Climate Change*. Cambridge University Press. Cambridge.
- James, K., Campbell, S., and Godlobe, C. (2002). *Watery: Taking Advantage of Untapped Energy and Water Efficiency Opportunities in Municipal Water Systems*. Alliance to Save Energy. Washington D.C.
- Jensen, P. K., Phuc, P. D., Dalsgaard, A., and Konradsen, F. (2013). Successful sanitation promotion must recognize the use of latrine wastes in agriculture — the example of Viet Nam. *Bulletin of the World Health Organization*. Retrieved January 16, 2013, from: <http://www.scielosp.org/>.
- Jönsson, H., Stingzing, A. R., Vinneras, B., and Salomon, E. (2004). *Guidelines on the Use of Urine and Faeces in Crop Production Report 2004-2*. Retrieved January 29, 2013, from: http://www.ecosanres.org/pdf_files/ESR_Publications_2004/ESR2web.pdf
- Kaiser, J. (2006). *An Analysis of the Use of Desiccant as a Method of Pathogen Removal in Compost Latrines in Rural Panama*. Master's Report, Michigan Technological University, Houghton, MI. Retrieved January 17, 2013, from: <http://usfmi.weebly.com/thesesreports.html>.
- Karlsson, J., and Larsson, M. (2000). *Composting of latrine products in Addis Ababa, Ethiopia*. Lulea University of Technology. Retrieved January 16, 2013, from: <http://epubl.ltu.se/1402-1617/2000/032/index-en.html>.
- Kosek, M., Bern, C., and Guerrant, R. L. (2003). The global burden of diarrhoeal disease, as estimated from studies published between 1992 and 2000. *WHO* 81, 197–204.
- Kumar, R., Gupta, M.K., and Kanwar, S.S. (1999). Fate of bacterial pathogens in cattle dung slurry subjected to anaerobic digestion. *World Journal of Microbiology and Biotechnology*, 15 (3), 335-338.
- Lansing, S., Botero Botero, R., and Martin, J. (2008). Waste treatment and biogas quality in small-scale agricultural digesters. *Bioresource Technology*, 99 (13), 5881-5890.
- Lind, B.B., Ban, Z., and Bydén, S. (2001). Volume reduction and concentration of nutrients in human urine. *Ecological Engineering*, 16 (4), 561-566.
- Massé, D., Croteau, F., and Masse, L. (2007). The fate of crop nutrients during digestion of swine manure in psychrophilic anaerobic sequencing batch reactors. *Bioresource Technology*, 98 (15), 2819–2823.

- Massé, D., Gilbert, Y., and Topp, E. (2011). Pathogen removal in farm-scale psychrophilic anaerobic digesters processing swine manure. *Bioresource Technology*, 102 (2), 641–646.
- Metcalf and Eddy. (2003). *Wastewater Engineering, Treatment and Reuse*. Tata McGraw-Hill. New Delhi.
- McGraw Hill. (1982). *Encyclopedia of Science and Technology*. McGraw Hill, Inc. New York, NY.
- Mehl, J., Kaiser, J., Hurtado, D., Gibson, D., Izurieta, R., and Mihelcic, J.R. (2011). Pathogen destruction and solids decomposition in composting latrines: study of fundamental mechanisms and user operation in rural Panama. *Journal of Water and Health*, 9 (1), 187-199.
- Mihelcic, J.R., Myre, E.A., Fry, L.M., Phillips, L.D., and Barkdoll, B.D. (2009). *Field Guide in Environmental Engineering for Development Workers: Water, Sanitation, Indoor Air*. American Society of Civil Engineers (ASCE) Press. Reston, VA.
- Mihelcic, J.R., Fry, L.M., and Shaw, R. (2011). Global potential of phosphorus recovery from human urine and feces. *Chemosphere*, 84 (6), 832-839.
- Mo, W., Zhang, Q., Mihelcic, J.R., and Hokanson, D.R. (2011). Embodied energy comparison of surface water and groundwater supply options. *Water Research*, 45 (17), 5577-5586.
- Mo, W. and Zhang, Q. (2012). Can municipal wastewater treatment systems be carbon neutral? *Journal of Environmental Management*, 112 (15), 360-367.
- Monroy, O., Fama, G., Meraz, M., Montoya, L., and Macarie, H. (2000). Anaerobic digestion for wastewater treatment in Mexico: state of the technology. *Water Resources*, 34 (6), 1803-1816.
- Morgan, P. (2007). Toilets That Make Compost: Low-cost, sanitary toilets that produce valuable compost for crops in an African context. Retrieved January 15, 2013, from: books.google.com.
- Muga, H. E. and Mihelcic, J. R.. (2008). Sustainability of wastewater treatment technologies. *Journal of Environmental Management*, 88 (3), 437-447.
- Municipality of Santo Domingo. (2008). *Plan de Desarrollo Concertado 2008-2011*. Piura: RAISAPP E.I.R.L.
- Nath K.J., Bloomfield S.F., and Jones, M. (2006). *Household water storage, handling and point-of-use treatment*. A review commissioned by IFH. Retrieved January 20, 2013, from: <http://www.ifh-homehygiene.org>.
- Ocwieja, S. (2010). *Life Cycle Thinking Assessment Applied to Three Biogas Projects in Central Uganda*. Michigan Technological University. Retrieved January 20, 2013, from: <http://usfmi.weebly.com/thesesreports.html>.

- Rittmann, B. and McCarty, P. (2001). *Environmental Biotechnology: Principles and Applications*. McGraw-Hill. New York.
- Richard T. and Trautmann N. (1996). *C/N Ratio*. The Cornell Composting Website. Retrieved January 17, 2008, from: http://compost.css.cornell.edu/calc/cn_ratio.html.
- Rowse, L. (2011). *Design of Small Scale Anaerobic Digesters for Application in Rural Developing Countries*. Master's Thesis. University of South Florida. Retrieved January 16, 2013, from: <http://usfmi.weebly.com/thesesreports.html>.
- Sahlström, L. (2003). A review of survival of pathogenic bacteria in organic waste used in biogas plants. *Bioresource Technology*, 87 (2), 161-166.
- Shaw, R. (2010). *The use of human urine as a crop fertilizer in Mali, West Africa*. Michigan Technological University. Retrieved online January 20, 2013, from: <http://usfmi.weebly.com/thesesreports.html>.
- Smith, K., Apte, M., Yuqing, M., Wongsekiarttirat, W., and Kulkarni, A. (1994). Air pollution and the energy ladder in asian cities. *Energy*, 19 (5), 587-600.
- Sobsey, M. D., Handzel, T., and Venczel, L. (2003). Chlorination and safe storage of household drinking water in developing countries to reduce waterborne disease. *Water Science and Technology*, 47 (3), 221-228.
- United Nations. (2006). UN Statistical Division. *Progress towards the Millennium Development Goals, 1990-2000*. The United Nations, New York.
- United States Department of Agriculture. (2008). *Agricultural Waste Management Field Handbook*. Washington D.C.
- Verbyla, M., Oakley, S., and Mihelcic, J.R. (2013). Wastewater infrastructure for small cities in an urbanizing world: Integrating the protection of human health and the environment with resource recovery and food security. *Environmental Science and Technology*, In press. <http://dx.doi.org/10.1021/es3050955>.
- Vinneras, B., Bjorklund, A., and Jonsson, H. (2003). Thermal composting of faecal matter as treatment and possible disinfection method--laboratory-scale and pilot-scale studies. *Bioresource Technology*, 88 (1), 47-54.
- Walekhwa, P., Mugisha, J., and Drake, L. (2009). Biogas energy from family-sized digesters in Uganda: Critical factors and policy implications. *Energy Policy*, 37 (7), 2754-2762.
- WHO/UNICEF. (2012). *Progress on Sanitation and Drinking-Water: 2012 Update*. Emerson, Wajdowicz Studios. New York.
- World Health Organization. (1996). *Fact Sheets on Environmental Sanitation*. Retrieved January 28, 2013, from: <http://helid.digicollection.org/en/>.
- World Health Organization. (2009). *The World Health Report 2004*. Geneva.

World Health Organization. (2008). *Water, Sanitation, and Health*. Retrieved January 8, 2013, from: http://www.who.int/water_sanitation_health/en/.

World Bank. (2013). World Development Indicators. Retrieved January, 2013, from: <http://data.worldbank.org/>.

Wang, X., Di, C., Hu, X., Wu, W., Jiang, X., and Jiang, S. (2007). The influence of using biogas digesters on family energy consumption and its economic benefit in rural areas— comparative study between Lianshui and Guichi in China. *Renewable and Sustainable Energy Reviews*, 11 (5), 1018-1024.

Yu, L., Yaoqiu, K., Ningsheng, H., Zhifeng, W., and Lianzhong, X. (2008). Popularizing household-scale biogas digesters for rural sustainable energy development and greenhouse gas mitigation. *Renewable Energy*, 33 (9), 2027-2035.

Zhu, N. (2007). Effect of low initial C/N ratio on aerobic composting of swine manure with rice straw. *Bioresource Technology*, 98 (1), 9-13.

Zimmerman, J.B., Mihelcic, J.R., Smith, J. (2008). Global Stressors on Water Quality and Quantity. *Environmental Science & Technology*, 42 (12), 4247-4254.

APPENDICES

Appendix A Material Inventories

Table A.1: Material inventory for VIP latrine adobe fiber cement privacy structure

Material	Unit	Quantity	Volume (m3)	Density (kg/m3)	Mass (kg)	Mode of Transport	Origin	Distance (km)
CEMENT PORTLAND TYPE I (42.5 kg)	BAG	2.50	0.05	2300.00	106.25	Camion	Pacasmayo	449
SAND, COURSE	m3	0.05	0.05	1600.00	80.00	Camion	Morropon	45.5
STONE 1" TO 2"	m3	0.03	0.03	2515.00	75.45	Camion	Morropon	45.5
WIRE, BLACK NO. 16	kg	0.25			0.25	Camion	Piura	130
REBAR 3/8" 9 m	UNIT	1.00	6.41E-04	7850.00	5.03	Camion	Lima	1108
WOOD BEAMS FOR FOUNDATION 2"x4"x1.8m	UNIT	4.00	3.78E-03	670.00	2.53	N/A	Local	0
VENTILATION HAT, PVC 4"	UNIT	1.00			0.25	Camion	Piura	130
TUBE, PVC 4" 3 m	m	1.00			1.36	Camion	Piura	130
ADOBE BRICK (30x30x10cm)	UNIT	300.00	0.01	1515.11	4090.80	N/A	Local	0
BRICK (22x12x8 cm)	UNIT	350	2.11E-03	1922.00	1420.74	Camion	Buenos Aires	63.1
NAILS FOR ETERNIT ROOF	UNIT	3.00			0.60	Camion	Piura	130
ETERNIT ROOF, GRAY 8" FIBRE CEMENT	UNIT	2.50	8.96E-03	1300.00	29.13	Camion	Piura	130
PLYWOOD	ft2	30.00	1.39E-03		3.01	Camion	Lima	1108
NAIL WITH "HAT" 2.5"	kg	0.50			0.50	Camion	Piura	130
WOOD BEAMS FOR FRAME	UNIT	4.00			Included in other items	N/A	Local	0
WOOD BEAMS FOR ROOF	UNIT	4.00			Included in other items	N/A	Local	0
SHEET METAL DOOR WITH FRAME, PADLOCK, AND RINGS (1.83m x 0.87m)	UNIT	1.00			included in other items	Camion	Piura	130
PLASTER, 20 kg	BAG	0.05			1.07	Camion	Piura	130

Appendix A (Continued)

Table A.2: Material inventory for VIP latrine brick corrugated metal privacy structure

Material	Unit	Quantity	Volume (m3)	Density (kg/m3)	Mass (kg)	Mode of Transport	Origin	Distance (km)
CEMENT PORTLAND TYPE I (42.5 kg)	BAG	5.50	0.10	2300.00	233.75	Camion	Pacasmayo	449
SAND, COURSE	m3	0.05	0.05	1600.00	80.00	Camion	Morropon	45.5
STONE 1" TO 2"	m3	0.03	0.03	2515.00	75.45	Camion	Morropon	45.5
WIRE, BLACK NO. 16	kg	0.25			0.25	Camion	Piura	130
REBAR 3/8" 9 m	UNIT	1.00	6.41E-04	7850.00	5.03	Camion	Lima	1108
WOOD BEAMS FOR FOUNDATION 2"x4"x1.8m	UNIT	4.00	3.78E-03	670.00	2.53	N/A	Local	0
VENTILATION HAT, PVC 4"	UNIT	1.00			0.25	Camion	Piura	130
TUBE, PVC 4" 3 m	m	1.00			1.36	Camion	Piura	130
BRICK (22x12x8 cm)	UNIT	750	2.11E-03	1922.00	3044.45	Camion	Buenos Aires	63.1
CORRUGATED METAL (2.4x0.8 m)	UNIT	2.5			10.03	Camion	Lima	1108
PLYWOOD	ft2	30.00	1.39E-03		-	Camion	Lima	1108
NAIL WITH "HAT" 2.5"	kg	0.50			0.50	Camion	Piura	130
WOOD BEAMS FOR FRAME	UNIT	4.00			included in other items	N/A	Local	0
WOOD BEAMS FOR ROOF	UNIT	4.00			included in other items	N/A	Local	0
SHEET METAL DOOR WITH FRAME, PADLOCK, AND RINGS (1.83m x 0.87m)	UNIT	1.00			included in other items	Camion	Piura	130
PLASTER, 20 kg	BAG	0.05			1.07	Camion	Piura	130

Appendix A (Continued)

Table A.3: Material inventory for VIP latrine adobe fiber cement privacy structure (unlined pit)

Material	Unit	Quantity	Volume (m3)	Density (kg/m3)	Mass (kg)	Mode of Transport	Origin	Distance (km)
CEMENT PORTLAND TYPE I (42.5 kg)	BAG	2.50	0.05	2300.00	106.25	Camion	Pacasmayo	449
SAND, COURSE	m3	0.05	0.05	1600.00	80.00	Camion	Morropon	45.5
STONE 1" TO 2"	m3	0.03	0.03	2515.00	75.45	Camion	Morropon	45.5
WIRE, BLACK NO. 16	kg	0.25			0.25	Camion	Piura	130
REBAR 3/8" 9 m	UNIT	1.00	6.41E-04	7850.00	5.03	Camion	Lima	1108
WOOD BEAMS FOR FOUNDATION 2"x4"x1.8m	UNIT	4.00	3.78E-03	670.00	2.53	N/A	Local	0
VENTILATION HAT, PVC 4"	UNIT	1.00			0.25	Camion	Piura	130
TUBE, PVC 4" 3 m	m	1.00			1.36	Camion	Piura	130
ADOBE BRICK (30x30x10cm)	UNIT	300.00	0.01	1515.11	4090.80	N/A	Local	0
BRICK (22x12x8 cm)	UNIT	350	2.11E-03	1922.00	1420.74	Camion	Buenos Aires	63.1
NAILS FOR ETERNIT ROOF	UNIT	3.00			0.60	Camion	Piura	130
ETERNIT ROOF, GRAY 8" FIBRE CEMENT	UNIT	2.50	8.96E-03	1300.00	29.13	Camion	Piura	130
PLYWOOD	ft2	30.00	1.39E-03		3.01	Camion	Lima	1108
NAIL WITH "HAT" 2.5"	kg	0.50			0.50	Camion	Piura	130
WOOD BEAMS FOR FRAME	UNIT	4.00			included in other items	N/A	Local	0
WOOD BEAMS FOR ROOF	UNIT	4.00			included in other items	N/A	Local	0
SHEET METAL DOOR WITH FRAME, PADLOCK, AND RINGS (1.83m x 0.87m)	UNIT	1.00			included in other items	Camion	Piura	130
PLASTER, 20 kg	BAG	0.05			1.07	Camion	Piura	130

Appendix A (Continued)

Table A.4: Material inventory for pour-flush latrine adobe fiber cement privacy structure

Material	Unit	Quantity	Volume (m3)	Density (kg/m3)	Mass (kg)	Mode of Transport	Origin	Distance (km)
CEMENT PORTLAND TYPE I (42.5 kg)	BAG	12.50	0.23	2300.00	531.25	Camion	Pacasmayo	449
SAND, COURSE	m3	0.78	0.78	1600.00	2855.59	Camion	Morropon	45.5
SAND, FINE	m3	0.74	0.74	1600.00	1190.40	Camion	Morropon	45.5
STONE 1/2" TO 3/4"	m3	1.73	1.73	2515.00	4888.26	Camion	Morropon	45.5
MIXED AGGREGATE, SAND AND STONE	m3	1.11	1.11	1922.00	included in other item	Camion	Morropon	45.5
WIRE, BLACK NO. 16	kg	2.10			2.10	Camion	Piura	130
WIRE, BLACK NO. 8	kg	0.32			0.32	Camion	Piura	130
REBAR 3/8" 9 m	UNIT	3.00	6.41E-04	7850.00	15.10	Camion	Lima	1108
NAILS FOR ETERNIT ROOF	UNIT	3.00			0.60	Camion	Piura	130
ETERNIT ROOF, GRAY 8" FIBRE CEMENT	UNIT	2.50	8.96E-03	1300.00	29.13	Camion	Lima	1108
ADOBE BRICKS (30x30x10cm)	UNIT	300.00	0.01	1515.11	4090.80	N/A	Local	0
BRICK (22x12x8 cm)	UNIT	350.00	2.11E-03	1922.00	1420.74	Camion	Buenos Aires	63.1
PLYWOOD	ft2	30.49	0.0014	670.00	-	N/A	Local	0
WOOD BEAMS 4"x4"x1.5 m	UNIT	4.00	0.0155	670.00	-	N/A	Local	0
HINGE 3"	UNIT	3.00			0.75	Camion	Piura	130
DOOR KNOB	UNIT	1.00			0.59	Camion	Piura	130
NAILS FOR WOOD C/C 1"	kg	0.10			0.10	Camion	Piura	130
NAILS FOR WOOD C/C 2"	kg	0.15			0.15	Camion	Piura	130
NAILS FOR WOOD C/C 3"	kg	0.64			0.64	Camion	Piura	130
NYLON MESH, MOSQUITO	m2	0.24			0.10	Camion	Piura	130
TOILET, PREFABRICATED	UNIT	1.00			34.11	Camion	Lima	1108
SINK, PREFABRICATED	UNIT	1.00			11.07	Camion	Piura	130
TOILET SEAT (PLASTIC)	UNIT	1.00			2.68	Camion	Piura	130
PLASTER 16 kg BAG	BAG	0.29			4.71	Camion	Piura	130
CONCRETE BOX FOR CONTROL VALVE	UNIT	1.00			20.00	Camion	Piura	130
VALVE PVC 1/2"	UNIT	1.00			1.10	Camion	Piura	130
ADAPTOR, PVC 1/2"	UNIT	3.00			0.30	Camion	Piura	130

Appendix A (Continued)

Table A.4: (Continued)

TUBE, PVC 1/2" 5m	UNIT	1.00			1.24	Camion	Piura	130
FAUCET, BRONZE 1/2"	UNIT	1.00			0.60	Camion	Piura	130
ELBOW, PVC 90 1/2"	UNIT	2.00			0.20	Camion	Piura	130
TEE, PVC 1/2"	UNIT	1.00			0.10	Camion	Piura	130
TUBE, PVC 2"	m	3.08			3.20	Camion	Piura	130
TUBE, PVC 4"	m	7.21			3.27	Camion	Piura	130
VENTILATION HAT, PVC 2"	UNIT	1.00			0.10	Camion	Piura	130
ELBOW, PVC 90 2"	UNIT	1.00			0.10	Camion	Piura	130
ELBOW, PVC 90 4"	UNIT	1.00			0.10	Camion	Piura	130
TEE PVC SAL 4"x2"	UNIT	1.00			0.10	Camion	Piura	130

Table A.5: Material inventory for pour-flush latrine brick corrugated metal privacy structure

Material	Unit	Quantity	Volume (m3)	Density (kg/m3)	Mass (kg)	Mode of Transport	Origin	Distance (km)
CEMENT PORTLAND TYPE I (42.5 kg)	BAG	15.50	0.29	2300.00	658.75	Camion	Pacasmayo	449
SAND, COURSE	m3	0.78	0.78	1600.00	2855.59	Camion	Morropon	45.5
SAND, FINE	m3	0.74	0.74	1600.00	1190.40	Camion	Morropon	45.5
STONE 1/2" TO 3/4"	m3	1.73	1.73	2515.00	4888.26	Camion	Morropon	45.5
MIXED AGGREGATE, SAND AND STONE	m3	1.11	1.11	1922.00	included in other item	Camion	Morropon	45.5
WIRE, BLACK NO. 16	kg	2.10			2.10	Camion	Piura	130
WIRE, BLACK NO. 8	kg	0.32			0.32	Camion	Piura	130
REBAR 3/8" 9 m	UNIT	3.00	6.41E-04	7850.00	15.10	Camion	Lima	1108
CORRUGATED METAL (2.4x0.8 m)	UNIT	2.5			10.03	Camion	Lima	1108
BRICK (22x12x8 cm)	UNIT	750.00	2.11E-03	1922.00	3044.45	Camion	Buenos Aires	63.1
PLYWOOD	ft2	30.49	0.0014	670.00		N/A	Local	0
WOOD BEAMS 4"x4"x1.5 m	UNIT	4.00	0.0155	670.00		N/A	Local	0

Appendix A (Continued)

Table: A.5 (Continued)

HINGE 3"	UNIT	3.00			0.75	Camion	Piura	130
DOOR KNOB	UNIT	1.00			0.59	Camion	Piura	130
NAILS FOR WOOD C/C 1"	kg	0.10			0.10	Camion	Piura	130
NAILS FOR WOOD C/C 2"	kg	0.15			0.15	Camion	Piura	130
NAILS FOR WOOD C/C 3"	kg	0.64			0.64	Camion	Piura	130
NYLON MESH, MOSQUITO	m2	0.24			0.10	Camion	Piura	130
TOILET, PREFABRICATED	UNIT	1.00			34.11	Camion	Lima	1108
SINK, PREFABRICATED	UNIT	1.00			11.07	Camion	Piura	130
TOILET SEAT (PLASTIC)	UNIT	1.00			2.68	Camion	Piura	130
PLASTER 16 kg BAG	BAG	0.29			4.71	Camion	Piura	130
PAINT, OCRE	kg	2.36			2.36	Camion	Piura	130
CONCRETE BOX FOR CONTROL VALVE	UNIT	1.00			20.00	Camion	Piura	130
VALVE PVC 1/2"	UNIT	1.00			1.10	Camion	Piura	130
ADAPTOR, PVC 1/2"	UNIT	3.00			0.30	Camion	Piura	130
TUBE, PVC 1/2" 5m	UNIT	1.00			1.24	Camion	Piura	130
FAUCET, BRONZE 1/2"	UNIT	1.00			0.60	Camion	Piura	130
ELBOW, PVC 90 1/2"	UNIT	2.00			0.20	Camion	Piura	130
TEE, PVC 1/2"	UNIT	1.00			0.10	Camion	Piura	130
TUBE, PVC 2"	m	3.08			3.20	Camion	Piura	130
TUBE, PVC 4"	m	7.21			3.27	Camion	Piura	130
VENTILATION HAT, PVC 2"	UNIT	1.00			0.10	Camion	Piura	130
ELBOW, PVC 90 2"	UNIT	1.00			0.10	Camion	Piura	130
ELBOW, PVC 90 4"	UNIT	1.00			0.10	Camion	Piura	130
TEE PVC SAL 4"x2"	UNIT	1.00			0.10	Camion	Piura	130

Appendix A (Continued)

Table A.6: Material inventory for composting latrine adobe fiber cement privacy structure

Material	Unit	Quantity	Volume (m3)	Density (kg/m3)	Mass (kg)	Mode of Transport	Origin	Distance (km)
ADOBE BRICK (0.3x0.3x0.1 m)	UNIT	300	9.00E-03	1515.11	4090.80	N/A	Local	0
SAND, COURSE	m3	0.567	0.57	1600.00	907.20	Camion	Morropon	45.5
SAND, SIFTED	m3	0.378	0.38	1600.00	604.80	Camion	Morropon	45.5
WOOD, 3 m (3 cm diameter)	PIECE	3	6.36E-07	670.00		N/A	Local	0
WOOD, 2.4 m (3 cm diameter)	PIECE	3	5.09E-07	670.00		N/A	Local	0
WOOD, 2"x0.25x1.5 m	PIECE	1	1.91E-02	670.00		N/A	Local	0
STONE, CRUSHED	m3	0.855	0.86	2515.00	2150.33	Camion	Morropon	45.5
STONE, MEDIUM	m3	0.414	0.41	2515.00	1041.21	Camion	Morropon	45.5
CEMENT PORTLAND TYPE I (42.5 kg)	BAG	9		2300.00	382.50	Camion	Pacasmayo	449
REBAR 1/2" 9 m	UNIT	3	1.14E-03	7850.00	26.85	Camion	Lima	1108
REBAR 1/4" 9 m	UNIT	0.52	1.14E-03	7850.00	4.65	Camion	Lima	1108
WIRE No. 16	kg	1.5			1.50	Camion	Piura	130
BRICK (22x12x8 cm)	UNIT	300	2.11E-03	1922.00	1217.78	Camion	Buenos Aires	63.1
TUBE, PVC 8" 5 m	UNIT	0.14			0.11	Camion	Piura	130
TUBE, PVC 2" 3 m	UNIT	2.5			8.00	Camion	Piura	130
ELBOW, PVC 2" 90	UNIT	6			1.00	Camion	Piura	130
TEE, PVC 2"	UNIT	1			0.10	Camion	Piura	130
TEE, PVC 4"	UNIT	1			0.10	Camion	Piura	130
ELBOW, PVC 4" 90	UNIT	1			0.10	Camion	Piura	130
TUBE, DESAGUE BLACK 4" 3 m	UNIT	1			1.36	Camion	Piura	130
VENTILATION HAT, PVC 4"	UNIT	1			0.10	Camion	Piura	130
NYLON MESH	m2	0.26			0.10	Camion	Piura	130
PLYWOOD	ft2	30	0.0014	670.00	0.93	Camion	Piura	130

Appendix A (Continued)

Table A.6: (Continued)

RUBBER	m2	0.05	1.50E-04	1522.00	0.23	Camion	Piura	130
HINGE, 3" WITH SCREWS	UNIT	5			1.75	Camion	Piura	130
LATCH, 1.5"	UNIT	2			0.25	Camion	Piura	130
ETERNIT ROOF, GRAY 8" FIBRE CEMENT	UNIT	2.50	8.96E-03	1300.00	29.13	Camion	Lima	1108
TOILET SEAT (PLASTIC)	UNIT	2			2.68	Camion	Piura	130
URINAL (PORCELAIN)	UNIT	1			15.40	Camion	Piura	130
SEPARATOR SEAT (FIBER GLASS)	UNIT	2			16.00	Camion	Piura	130
PLASTIC SHEET (DOUBLE WIDE 1.5)	m	3			0.90	Camion	Piura	130

Table A.7: Material inventory for composting latrine brick corrugated metal privacy structure

Material	Unit	Quantity	Volume (m3)	Density (kg/m3)	Mass (kg)	Mode of Transport	Origin	Distance (km)
SAND, COURSE	m3	0.567	0.57	1600.00	907.20	Camion	Morropon	45.5
SAND, SIFTED	m3	0.378	0.38	1600.00	604.80	Camion	Morropon	45.5
WOOD, 3 m (3 cm diameter)	PIECE	3	6.36E-07	670.00	-	N/A	Local	0
WOOD, 2.4 m (3 cm diameter)	PIECE	3	5.09E-07	670.00	-	N/A	Local	0
WOOD, 2"x0.25x1.5 m	PIECE	1	1.91E-02	670.00	-	N/A	Local	0
STONE, CRUSHED	m3	0.855	0.86	2515.00	2150.33	Camion	Morropon	45.5
STONE, MEDIUM	m3	0.414	0.41	2515.00	1041.21	Camion	Morropon	45.5
CEMENT PORTLAND TYPE I (42.5 kg)	BAG	11		2300.00	467.50	Camion	Pacasmayo	449
REBAR 1/2" 9 m	UNIT	3	1.14E-03	7850.00	26.85	Camion	Lima	1108
REBAR 1/4" 9 m	UNIT	0.52	1.14E-03	7850.00	4.65	Camion	Lima	1108
WIRE No. 16	kg	1.5			1.50	Camion	Piura	1108
BRICK (22x12x8 cm)	UNIT	600	2.11E-03	1922.00	2435.56	Camion	Buenos Aires	63.1
TUBE, PVC 8" 5 m	UNIT	0.14			0.11	Camion	Piura	130

Appendix A (Continued)

Table A.7: (Continued)

TUBE, PVC 2" 3 m	UNIT	2.5			8.00	Camion	Piura	130
ELBOW, PVC 2" 90	UNIT	6			1.00	Camion	Piura	130
TEE, PVC 2"	UNIT	1			0.10	Camion	Piura	130
TEE, PVC 4"	UNIT	1			0.10	Camion	Piura	130
ELBOW, PVC 4" 90	UNIT	1			0.10	Camion	Piura	130
TUBE, DESAGUE BLACK 4" 3 m	UNIT	1			1.36	Camion	Piura	130
VENTILATION HAT, PVC 4"	UNIT	1			0.10	Camion	Piura	130
NYLON MESH	m2	0.26			0.10	Camion	Piura	130
PLYWOOD	ft2	30	0.0014	670.00	0.93	Camion	Piura	130
RUBBER	m2	0.05	1.50E-04	1522.00	0.23	Camion	Piura	130
HINGE, 3" WITH SCREWS	UNIT	5			1.75	Camion	Piura	130
LATCH, 1.5"	UNIT	2			0.25	Camion	Piura	130
CORRUGATED METAL (2.4x0.8 m)	UNIT	2.5			10.03	Camion	Lima	1108
DOOR KIT (WOOD WITH SCREWS)	KIT	1	4.48E-03	670.00	3.00	Camion	Piura	130
TOILET SEAT (PLASTIC)	UNIT	2			2.68	Camion	Piura	130
URINAL (PORCELAIN)	UNIT	1			15.40	Camion	Piura	130
SEPARATOR SEAT (FIBER GLASS)	UNIT	2			16.00	Camion	Piura	130
PLASTIC SHEET (DOUBLE WIDE 1.5)	m	3			0.90	Camion	Piura	130

Appendix A (Continued)

Table A.8: Material inventory for biodigester latrine adobe fiber cement privacy structure

Material	Unit	Quantity	Volume (m3)	Density (kg/m3)	Mass (kg)	Mode of Transport	Origin	Distance (km)
REACTOR 10m3 (8x1.42 m) GEOMEMBRANE 0.6 mm thick	UNIT	1.00	2.24E-02	1400.00	34.00	Camion	Lima	1108
GAS RESERVOIR (2.2x0.9 m)	UNIT	1.00	4.50E-03	1400.00	10.00	Camion	Lima	1108
PLASTIC, BLACK (1.5 m wide)	m	18.00			5.36	Camion	Piura	130
PLASTIC, TRANSPARENT (1.5 wide)	m	10.00			2.98	Camion	Piura	130
CEMENT PORTLAND TYPE 1 (42.5 kg)	BAG	12.80			544.00	Camion	Pacasmayo	449
BRICK (22x12x8 cm)	UNIT	150.00	2.11E-03	1922.00	608.89	Camion	Buenos Aires	63.1
ADOBE BRICK (30x30x10cm)	UNIT	500.00	0.01	1515.11	6818.00	N/A	Local	0
SAND, COURSE	m3	0.53		1600.00	843.76	Camion	Morropon	45.5
SAND, FINE	m3	0.83		1600.00	1328.00	Camion	Morropon	45.5
STONE, 1/2" TO 3/4"	m3	1.11		2515.00	2826.25	Camion	Morropon	45.5
MIXED AGGREGATE, SAND AND STONE	m3	0.07		1922.00	included in other item	Camion	Morropon	45.5
WIRE, BLACK No. 16	kg	2.10			2.10	Camion	Piura	130
WIRE, BLACK No. 8	kg	0.32			0.32	Camion	Piura	130
DRY GRASS	BUSHEL	1.00			20.00	N/A	Local	0
CHICKEN WIRE (1x1 cm)	m	1.00			1.00	Camion	Piura	130
TUBE PVC 1/2" 5 m	UNIT	6.00			7.44	Camion	Piura	130
VALVE PVC 1/2"	UNIT	3.00			0.30	Camion	Piura	130
TEE PVC 1/2"	UNIT	6.00			0.60	Camion	Piura	130
ELBOW PVC 1/2"	UNIT	5.00			0.50	Camion	Piura	130
COUPLING 1" TO 1/2" (GAS EXIT)	UNIT	3.00			0.30	Camion	Piura	130
NIPPLE FOR HOSE CONNECTION 1/2" TO 3/8"	UNIT	5.00			0.50	Camion	Piura	130
HOSE, GAS 3/8"	m	7.00			1.00	Camion	Piura	130
HOSE CLAMP 3/8"	UNIT	5.00			0.50	Camion	Piura	130

Appendix A (Continued)

Table A.8: (Continued)

HOOKS FOR TUBE 1/2"	BAG	5.00			0.50	Camion	Piura	130
VALVE 2"	UNIT	1.00			0.10	Camion	Piura	130
REDUCTION PVC 6" TO 4"	UNIT	1.00			0.10	Camion	Piura	130
STOVE, TABLE TOP 2 BURNERS	UNIT	1.00			4.00	Camion	Piura	130
NAILS, MIXED	kg	2.00			2.00	Camion	Piura	130
NAILS FOR ETERNIT ROOF	UNIT	3.00			0.60	Camion	Piura	130
ETERNIT ROOF, GRAY 8"	UNIT	2.50	8.96E-03	1300.00	29.13	Camion	Lima	1108
PLYWOOD	ft2	30.49	0.0014	670.00	-	Camion	Piura	130
WOOD BEAMS 4"x4"x1.5 m	UNIT	4.00	0.0619	670.00	-	N/A	Local	0
HINGE 3"	UNIT	3.00			0.75	Camion	Piura	130
DOOR KNOB	UNIT	1.00			0.59	Camion	Piura	130
NAILS FOR WOOD C/C 1"	kg	0.10			0.10	Camion	Piura	130
NAILS FOR WOOD C/C 2"	kg	0.15			0.15	Camion	Piura	130
NAILS FOR WOOD C/C 3"	kg	0.64			0.64	Camion	Piura	130
NYLON MESH, MOSQUITO	m2	0.24			0.10	Camion	Piura	130
TOILET, PREFABRICATED	UNIT	1.00			34.11	Camion	Piura	130
SINK, PREFABRICATED	UNIT	1.00			11.07	Camion	Piura	130
TOILET SEAT (PLASTIC)	UNIT	1.00			2.68	Camion	Piura	130
PLASTER 16kg BAG	BAG	0.29			4.71	Camion	Piura	130
CONCRETE BOX FOR CONTROL VALVE	UNIT	1.00			20.00	Camion	Piura	130
ADAPTOR, PVC 1/2"	UNIT	3.00			0.30	Camion	Piura	130
FAUCET, BRONZE 1/2"	UNIT	1.00			0.60	Camion	Piura	130
ELBOW, PVC 90 1/2"	UNIT	2.00			0.20	Camion	Piura	130
TUBE, PVC 2" 3 m	UNIT	1.00			3.00	Camion	Piura	130
TUBE, PVC 4"	m	7.21			3.27	Camion	Piura	130
VENTILATION HAT, PVC 2"	UNIT	1.00			0.10	Camion	Piura	130

Appendix A (Continued)

Table A.8: (Continued)

VENTILATION HAT, PVC 2"	UNIT	1.00			0.10	Camion	Piura	130
ELBOW, PVC 90 2"	UNIT	1.00			0.10	Camion	Piura	130
ELBOW, PVC 90 4"	UNIT	1.00			0.10	Camion	Piura	130
TEE PVC SAL 4" x 2"	UNIT	1.00			0.10	Camion	Piura	130
"Y" PVC 4"	UNIT	1.00			0.10	Camion	Piura	130

Table A.9: Material inventory for biodigester latrine brick corrugated metal privacy structure

Material	Unit	Quantity	Volume (m3)	Density (kg/m3)	Mass (kg)	Mode of Transport	Origin	Distance (km)
REACTOR 10m3 (8x1.42 m) GEOMEMBRANE 0.6 mm thick	UNIT	1.00	2.24E-02	1400.00	34.00	Camion	Lima	1108
GAS RESERVOIR (2.2x0.9 m)	UNIT	1.00	4.50E-03	1400.00	10.00	Camion	Lima	1108
PLASTIC, BLACK (1.5 m wide)	m	18.00			5.36	Camion	Piura	130
PLASTIC, TRANSPARENT (1.5 wide)	m	10.00			2.98	Camion	Piura	130
CEMENT PORTLAND TYPE 1 (42.5 kg)	BAG	15.80			671.50	Camion	Pacasmayo	449
BRICK (22x12x8 cm)	UNIT	550.00	2.11E-03	1922.00	2232.60	Camion	Buenos Aires	63.1
ADOBE BRICK (30x30x10cm)	UNIT	200.00	0.01	1515.11	2727.20	N/A	Local	0
SAND, COURSE	m3	0.53		1600.00	843.76	Camion	Morropon	45.5
SAND, FINE	m3	0.83		1600.00	1328.00	Camion	Morropon	45.5
STONE, 1/2" TO 3/4"	m3	1.11		2515.00	2826.25	Camion	Morropon	45.5
MIXED AGGREGATE, SAND AND STONE	m3	0.07		1922.00	included in other item	Camion	Morropon	45.5
WIRE, BLACK No. 16	kg	2.10			2.10	Camion	Piura	130
WIRE, BLACK No. 8	kg	0.32			0.32	Camion	Piura	130
DRY GRASS	BUSHEL	1.00			20.00	N/A	Local	0
CHICKEN WIRE (1x1 cm)	m	1.00			1.00	Camion	Piura	130

Appendix A (Continued)

Table A.9: (Continued)

TUBE PVC 1/2" 5 m	UNIT	6.00			7.44	Camion	Piura	130
VALVE PVC 1/2"	UNIT	3.00			0.30	Camion	Piura	130
TEE PVC 1/2"	UNIT	6.00			0.60	Camion	Piura	130
ELBOW PVC 1/2"	UNIT	5.00			0.50	Camion	Piura	130
COUPLING 1" TO 1/2" (GAS EXIT)	UNIT	3.00			0.30	Camion	Piura	130
NIPPLE FOR HOSE CONNECTION 1/2" TO 3/8"	UNIT	5.00			0.50	Camion	Piura	130
HOSE, GAS 3/8"	m	7.00			1.00	Camion	Piura	130
HOSE CLAMP 3/8"	UNIT	5.00			0.50	Camion	Piura	130
HOOKS FOR TUBE 1/2"	BAG	5.00			0.50	Camion	Piura	130
VALVE 2"	UNIT	1.00			0.10	Camion	Piura	130
REDUCTION PVC 6" TO 4"	UNIT	1.00			0.10	Camion	Piura	130
STOVE, TABLE TOP 2 BURNERS	UNIT	1.00			4.00	Camion	Piura	130
NAILS, MIXED	kg	2.00			2.00	Camion	Piura	130
BAMBOO, 4 m	UNIT	4.00				Camion	Piura	130
CORRUGATED METAL (2.4x0.8 m)	UNIT	2.5			10.03	Camion	Lima	1108
PLYWOOD	ft2	30.49	0.0014	670.00	-	Camion	Piura	130
WOOD BEAMS 4"x4"x1.5 m	UNIT	4.00	0.0619	670.00	-	N/A	Local	0
HINGE 3"	UNIT	3.00			0.75	Camion	Piura	130
DOOR KNOB	UNIT	1.00			0.59	Camion	Piura	130
NAILS FOR WOOD C/C 1"	kg	0.10			0.10	Camion	Piura	130
NAILS FOR WOOD C/C 2"	kg	0.15			0.15	Camion	Piura	130
NAILS FOR WOOD C/C 3"	kg	0.64			0.64	Camion	Piura	130
NYLON MESH, MOSQUITO	m2	0.24			0.10	Camion	Piura	130
TOILET, PREFABRICATED	UNIT	1.00			34.11	Camion	Piura	130
SINK, PREFABRICATED	UNIT	1.00			11.07	Camion	Piura	130
TOILET SEAT (PLASTIC)	UNIT	1.00			2.68	Camion	Piura	130

Appendix A (Continued)

Table A.9: (Continued)

PLASTER 16kg BAG	BAG	0.29			4.71	Camion	Piura	130
CONCRETE BOX FOR CONTROL VALVE	UNIT	1.00			20.00	Camion	Piura	130
ADAPTOR, PVC 1/2"	UNIT	3.00			0.30	Camion	Piura	130
FAUCET, BRONZE 1/2"	UNIT	1.00			0.60	Camion	Piura	130
ELBOW, PVC 90 1/2"	UNIT	2.00			0.20	Camion	Piura	130
TUBE, PVC 2" 3 m	UNIT	1.00			3.00	Camion	Piura	130
TUBE, PVC 4"	m	7.21			3.27	Camion	Piura	130
VENTILATION HAT, PVC 2"	UNIT	1.00			0.10	Camion	Piura	130
ELBOW, PVC 90 2"	UNIT	1.00			0.10	Camion	Piura	130
ELBOW, PVC 90 4"	UNIT	1.00			0.10	Camion	Piura	130
TEE PVC SAL 4" x 2"	UNIT	1.00			0.10	Camion	Piura	130
"Y" PVC 4"	UNIT	1.00			0.10	Camion	Piura	130

Appendix B LCA Results Data

Table B.1: LCA results for construction and use phase of VIP latrine adobe fiber cement privacy structure

Construction phase	Unit	Input	CED (MJ)	GWP (kgCO ₂ eq)
Brick, at plant/RER S	kg	1,420.7	4,019.7	337.9
Transport, lorry 3.5-16t, fleet average/RER S	kgkm	182,581.9	751.2	43.2
Portland cement, strength class Z 42.5, at plant/CH S	kg	106.3	403.5	87.3
Fibre cement corrugated slab, at plant/CH S	kg	29.1	267.6	19.9
PVC pipe E	kg	1.4	92.4	4.4
Plywood, outdoor use, at plant/RER S	m ³	1.40E-03	49.6	0.9
Sawn timber, softwood, planed, air dried, at plant/RER S	m ³	3.78E-03	40.9	0.3
Steel rebar, blast furnace and electric arc furnace route, production mix, at plant GLO S	kg	5.0	53.5	5.2
PVC (emulsion polymerisation) E	kg	0.3	17.2	0.8
Iron and steel, production mix/US	kg	1.6	16.6	1.4
Sand, at mine/CH S	kg	80.0	4.6	0.2
Gravel, round, at mine/CH S	kg	75.5	4.4	0.2
Stucco, at plant/CH S	kg	1.6	2.3	0.1
Adobe brick	kg	4,090.8	-	-

Total construction phase			5,723.6	501.8
---------------------------------	--	--	----------------	--------------

Use phase	Unit	Input	CED (MJ)	GWP (kgCO ₂ eq)
Brick, at plant/RER S	kg	1,420.7	4,019.7	337.9
Transport, lorry 3.5-16t, fleet average/RER S	kgkm	182,581.9	751.2	43.2
Portland cement, strength class Z 42.5, at plant/CH S	kg	106.3	403.5	87.3
Fibre cement corrugated slab, at plant/CH S	kg	29.1	267.6	19.9
PVC pipe E	kg	1.4	92.4	4.4
Plywood, outdoor use, at plant/RER S	m ³	1.40E-03	49.6	0.9
Sawn timber, softwood, planed, air dried, at plant/RER S	m ³	3.78E-03	40.9	0.3
Steel rebar, blast furnace and electric arc furnace route, production mix, at plant GLO S	kg	5.0	53.5	5.2
PVC (emulsion polymerisation) E	kg	0.3	17.2	0.8
Iron and steel, production mix/US	kg	1.6	16.6	1.4
Sand, at mine/CH S	kg	80.0	4.6	0.2
Gravel, round, at mine/CH S	kg	75.5	4.4	0.2
Stucco, at plant/CH S	kg	1.6	2.3	0.1
Adobe brick	kg	4,090.8	-	-

Appendix B (Continued)

Table B.1: (Continued)

Carbon dioxide (100% anaerobic)	kg	1,401.4	-	1,401.5
Methane (100% anaerobic)	kg	509.6	-	12,740.5
Total use phase (100% anaerobic)			5,723.6	14,643.7
Carbon dioxide (50% anaerobic)	kg	1,268.5	-	1,268.5
Methane (50% anaerobic)	kg	254.8	-	6,370.3
Total use phase (50% anaerobic)			5,723.6	8,140.5
Total (100% anaerobic)			11,447.1	15,145.5
Total 50% anaerobic)			11,447.1	8,642.2

Table B.2: LCA results for construction phase of VIP latrine brick corrugated metal privacy structure

Construction phase	Unit	Input	CED (MJ)	GWP (kgCO₂ eq)
Brick, at plant/RER S	kg	3,044.5	8,613.8	724.1
Transport, lorry 3.5-16t, fleet average/RER S	kgkm	358,860.2	1,588.7	126.9
Portland cement, strength class Z 42.5, at plant/CH S	kg	233.8	887.8	192.0
Galvanized steel sheet, at plant/RNA	kg	10.03	297.3	27.2
PVC pipe E	kg	1.36	92.4	4.4
Plywood, outdoor use, at plant/RER S	m3	0.0014	49.6	0.9
Sawn timber, softwood, planed, air dried, at plant/RER S	m3	0.00378	40.9	0.3
Steel rebar, blast furnace and electric arc furnace route, production mix, at plant S	kg	5.03	53.5	5.17
PVC (emulsion polymerisation) E	kg	0.25	17.2	0.8
Iron and steel, production mix/US	kg	1.6	16.6	1.4
Sand, at mine/CH S	kg	80	4.6	0.2
Gravel, round, at mine/CH S	kg	75.45	4.4	0.2
Stucco, at plant/CH S	kg	1.6	1.5	0.1
Total construction phase			11,668.2	1,083.7

Appendix B (Continued)

Table B.3: LCA results for construction phase of VIP latrine adobe fiber cement (unlined pit) privacy structure

Construction phase	Unit	Input	CED (MJ)	GWP (kgCO ₂ eq)
Fibre cement corrugated slab, at plant/CH S	kg	29.13	267.6	19.9
Transport, lorry 3.5-16t, fleet average/RER S	kgkm	29,236.5	130.7	7.5
PVC pipe E	kg	1.36	92.4	4.4
Portland cement, strength class Z 42.5, at plant/CH S	kg	21.25	80.7	17.5
Plywood, outdoor use, at plant/RER S	m3	0.0014	49.6	0.9
Sawn timber, softwood, planed, air dried, at plant/RER S	m3	0.00378	40.9	0.3
Steel rebar, blast furnace and electric arc furnace route, production mix, at plant GLO S	kg	5.03	53.5	5.2
PVC (emulsion polymerisation) E	kg	0.25	17.2	0.8
Steel, billets, at plant/US	kg	1.6	16.6	1.4
Sand, at mine/CH S	kg	80	4.6	0.2
Gravel, round, at mine/CH S	kg	75.45	4.4	0.2
Stucco, at plant/CH S	kg	1.6	2.3	0.1
Adobe brick	kg	4090.8	-	-
Total construction phase			760.4	58.4

Appendix B (Continued)

Table B.4: LCA results for construction and use phase of pour-flush latrine adobe fiber cement privacy structure

Construction phase	Unit	Input	CED (MJ)	GWP (kgCO ₂ eq)
Brick, at plant/RER S	kg	1,420.7	4,019.7	337.9
Transport, lorry 3.5-16t, fleet average/RER S	kgkm	828,850.8	3,788.3	217.7
Portland cement, strength class Z 42.5, at /CH S	kg	531.3	2,017.7	436.3
Sanitary ceramics, at regional storage/CH S	kg	45.2	1,941.6	105.7
PVC pipe E	kg	7.7	523.9	24.9
Steel rebar, blast furnace and electric arc furnace route, production mix, at plant GLO S	kg	15.1	161.0	15.5
Gravel, round, at mine/CH S	kg	4,888.3	283.1	11.7
Fibre cement corrugated slab, at plant/CH S	kg	29.1	267.6	19.9
Sand, at mine/CH S	kg	4,046.0	234.3	9.7
Sawn timber, planed, air dried, at plant/RER S	m3	1.55E-02	167.6	1.3
PVC injection moulding E	kg	1.1	105.2	3.2
Plywood, outdoor use, at plant/RER S	m3	0.0	50.3	0.9
Iron and steel, production mix/US	kg	2.2	46.4	4.0
Bronze, at plant/CH S	kg	0.6	30.3	1.7
Gypsum plaster (CaSO ₄ hemihydrates) DE S	kg	4.7	16.9	1.1
Pre-cast concrete, min. reinf., prod. mix, concrete type C20/25 RER S	kg	20.0	13.2	2.4
Adobe brick	kg	4,090.8	-	-

Total construction phase			13,667.0	1,193.9
---------------------------------	--	--	-----------------	----------------

Use phase				
Brick, at plant/RER S	kg	1,420.7	4,019.7	337.9
Portland cement, strength class Z 42.5, /CH S	kg	106.3	403.5	87.3
Steel rebar, blast furnace and electric arc furnace route, production mix, at plant GLO S	kg	15.1	161.0	15.5
Transport, lorry 3.5-16t, fleet average/RER S	kgkm	47,706.3	213.2	12.2

Carbon dioxide (100% anaerobic)	kg	1,401.4	-	1,401.5
Methane (100% anaerobic)	kg	509.6	-	12,740.5
Total use phase (100% anaerobic)			4,797.5	14,142.0
Carbon dioxide (50% anaerobic)	kg	1,268.5	-	1,268.5
Methane (50% anaerobic)	kg	254.8	-	6,370.3
Total use phase (50% anaerobic)			4,797.5	8,091.6

Total (100% anaerobic)			18,464.4	15,788.8
Total (50% anaerobic)			18,464.4	9,285.5

Appendix B (Continued)

Table B.5: LCA results for construction phase of pour-flush latrine brick corrugated metal privacy structure

Construction phase	Unit	Input	CED (MJ)	GWP (kgCO ₂ eq)
Brick, at plant/RER S	kg	3,044.45	8,613.8	724.1
Transport, lorry 3.5-16t, fleet average/RER S	kgkm	358,860.2	1,588.7	126.9
Portland cement, strength class Z 42.5, at plant/CH S	kg	233.75	887.8	192.0
Galvanized steel sheet, at plant/RNA	kg	10.03	297.3	27.2
PVC pipe E	kg	1.36	92.4	4.4
Plywood, outdoor use, at plant/RER S	m ³	0.0014	49.6	0.9
Sawn timber, softwood, planed, air dried, at plant/RER S	m ³	0.00378	40.9	0.3
Steel rebar, blast furnace and electric arc furnace route, production mix, at plant S	kg	5.03	53.5	5.17
PVC (emulsion polymerisation) E	kg	0.25	17.2	0.8
Iron and steel, production mix/US	kg	1.6	16.6	1.4
Sand, at mine/CH S	kg	80	4.6	0.2
Gravel, round, at mine/CH S	kg	75.45	4.4	0.2
Stucco, at plant/CH S	kg	1.6	1.5	0.1
Total construction phase			11,668.2	1,083.7

Appendix B (Continued)

Table B.6: LCA results for construction and use phase of composting latrine adobe fiber cement privacy structure

Construction phase	Unit	Input	CED (MJ)	GWP (kgCO ₂ eq)
Brick, at plant/RER S	kg	1,217.8	3,445.5	289.7
Transport, lorry 3.5-16t, fleet average/RER S	kgkm	536,748.8	2,482.6	142.6
Portland cement, strength class Z 42.5, at plant/CH S	kg	382.5	1,452.7	314.1
Sanitary ceramics, at regional storage/CH S	kg	31.4	1,349.4	73.5
PVC pipe E	kg	9.5	643.5	30.6
Steel rebar, blast furnace and electric arc furnace route, production mix, at plant GLO S	kg	31.5	335.0	32.4
Polypropylene injection moulding E	kg	3.6	418.1	15.8
Gravel, crushed, at mine/CH S	kg	2,150.3	296.7	9.4
Fibre cement corrugated slab, at plant/CH S	kg	29.1	267.6	19.9
Sawn timber, softwood, planed, air dried, at plant/RER S	m3	2.35E-02	254.0	2.0
PVC injection moulding E	kg	1.0	95.6	2.9
Sand, at mine/CH S	kg	1,512.0	87.6	3.6
Gravel, round, at mine/CH S	kg	1,041.2	60.3	2.5
Plywood, outdoor use, at plant/RER S	kg	1.40E-03	49.6	0.9
Iron and steel, production mix/US	kg	3.5	36.4	3.1
Adobe brick	kg	4,090.8	-	-
Total construction phase			11,274.7	943.0
Use phase without Resource Recovery				
Carbon dioxide	kg	1,135.4	-	1,135.4
Methane	kg	-	-	-
Use phase with Resource Recovery				
Carbon dioxide	kg	1,135.4	-	1,135.4
Methane	kg	-	-	-
Fertilizer use avoided (N)	kg	442.6	-29,332.9	-1,462.2
Total without Resource Recovery			11,274.7	2,078.5
Total with Resource Recovery			-18,058.2	616.2

Appendix B (Continued)

Table B.7: LCA results for construction phase of composting latrine brick corrugated metal privacy structure

Construction phase	Unit	Input	CED (MJ)	GWP (kgCO ₂ eq)
Brick, at plant/RER S	kg	2,435.6	6,891.0	579.3
Transport, lorry 3.5-16t, fleet average/RER S	kgkm	662,872.6	3,046.3	175.0
Portland cement, strength class Z 42.5, at plant/CH S	kg	467.5	1,775.5	383.9
Sanitary ceramics, at regional storage/CH S	kg	31.4	1,349.4	73.5
PVC pipe E	kg	9.5	643.5	30.6
Steel rebar, blast furnace and electric arc furnace route, production mix, at plant GLO S	kg	31.5	335.0	32.4
Polypropylene injection moulding E	kg	3.58	418.1	15.8
Gravel, crushed, at mine/CH S	kg	2,150.33	296.7	9.4
Galvanized steel sheet, at plant/RNA	kg	10.03	297.3	27.2
Sawn timber, softwood, planed, air dried, at plant/RER S	m3	0.0235	254.0	2.0
PVC injection moulding E	kg	1	95.6	2.9
Sand, at mine/CH S	kg	1512	87.6	3.6
Gravel, round, at mine/CH S	kg	1,041.21	60.3	2.5
Plywood, outdoor use, at plant/RER S	kg	0.0014	49.6	0.9
Iron and steel, production mix/US	kg	3.5	36.4	3.1
Total construction phase			15,636.3	1,342.1

Appendix B (Continued)

Table B.8: LCA results for construction and use phase of biodigester latrine adobe fiber cement privacy structure

Construction phase	Unit	Input	CED (MJ)	GWP (kgCO₂ eq)
Transport, lorry 3.5-16t, fleet average/RER S	kgkm	676,569.4	2,928.6	168.3
Polyvinylchloride, bulk polymerised, at plant/RER S	kg	44.0	2,665.2	87.3
Portland cement, strength class Z 42.5, at plant/CH S	kg	544.0	2,066.1	446.7
Sanitary ceramics, at regional storage/CH S	kg	45.2	1,941.6	105.7
Brick, at plant/RER S	kg	608.9	1,722.8	144.8
PVC pipe E	kg	12.7	860.9	41.0
Sawn timber, softwood, planed, air dried, at plant/RER S	m3	0.1	669.2	5.3
Polyethylene low density granulate (PE-LD), production mix, at plant RER	kg	8.3	614.5	17.5
Polypropylene injection moulding E	kg	3.0	353.9	13.4
Fibre cement corrugated slab, at plant/CH S	kg	29.1	267.6	19.9
Gravel, round, at mine/CH S	kg	2,826.3	163.7	6.8
Iron and steel, production mix/US	kg	9.0	137.8	11.9
Sand, at mine/CH S	kg	2,171.8	125.8	5.2
Gypsum plaster (CaSO ₄ alpha hemihydrates) DE S	kg	4.7	16.9	4.9
Plywood, outdoor use, at plant/RER S	m3	1.40E-03	49.6	0.9
Bronze, at plant/CH S	kg	0.6	30.3	1.7
Pre-cast concrete, min. reinf., prod. mix, concrete type C20/25, w/o consideration of casings RER S	kg	20.0	13.2	2.4
Adobe brick	kg	6,818.0	-	-
Total construction phase			14,627.5	1,083.6
Use phase general				
Polyvinylchloride, bulk polymerised, at plant/RER S	kg	81.8	4,957.2	162.5
Transport, lorry 3.5-16t, fleet average/RER S	kgkm	90,678.7	405.2	23.3
Use phase without Resource Recovery				
Carbon dioxide	kg	4,460.1	-	4,460.1
Methane	kg	1,757.0	-	43,925.8
Total use phase without Resource Recovery			5,362.4	48,571.6
Total without Resource Recovery			19,989.9	49,655.2

Appendix B (Continued)

Table B.8: (Continued)

Use phase with Resource Recovery				
Carbon dioxide	kg	9,293.1	-	9,293.1
Methane	kg	-	-	-
Natural gas use avoided	m3	2,473.7	-95,324.7	-810.9
Fertilizer use avoided (N)	kg	2,382.0	-157,864.8	-7,869.4
Total use phase with Resource Recovery			-247,827.1	798.6
Total with Resource Recovery			-233,199.6	1,882.2

Use phase without Resource Recovery with Flaring				
Carbon dioxide	kg	9,293.1	-	9,293.1
Methane	kg	-	-	-
Total use phase without Resource Recovery with Flaring			5,362.4	9,478.8
Total without Resource Recovery with Flaring			19,989.9	10,562.4

Table B.9: LCA results for biodigester latrine brick corrugated metal privacy structure

Construction phase	Unit	Input	CED (MJ)	GWP (kgCO₂ eq)
Brick, at plant/RER S	kg	2,232.6	6,316.8	531.0
Transport, lorry 3.5-16t, fleet average/RER S	kgkm	831,607.3	3,716.4	213.5
Polyvinylchloride, bulk polymerised, at plant/RER S	kg	44	2,665.2	87.3
Portland cement, strength class Z 42.5, at plant/CH S	kg	671.5	2,550.3	551.4
Sanitary ceramics, at regional storage/CH S	kg	45.18	1,941.6	105.7
PVC pipe E	kg	12.67	860.9	41.0
Sawn timber, softwood, planed, air dried, at plant/RER S	m3	0.0619	669.2	5.3
Polyethylene low density granulate (PE-LD), production mix, at plant RER	kg	8.34	614.5	17.5
Polypropylene injection moulding E	kg	3.03	353.9	13.4
Galvanized steel sheet, at plant/RNA	kg	10.03	297.3	27.2
Gravel, round, at mine/CH S	kg	2,826.25	163.7	6.8
Sand, at mine/CH S	kg	2,171.76	125.8	5.2
Steel, billets, at plant/US	kg	9.02	102.2	8.8
Plywood, outdoor use, at plant/RER S	m3	0.0014	49.6	0.9
Bronze, at plant/CH S	kg	0.6	30.3	1.7
Gypsum plaster (CaSO ₄ alpha hemihydrates) DE S	kg	4.71	16.9	1.1
Pre-cast concrete, min. reinf., prod. mix, concrete type C20/25, w/o consideration of casings RER S	kg	20	13.2	2.4
Adobe brick	kg	2,727.198	-	-
Total construction phase			20,474.4	1,620.2

Appendix C Permissions

C.1 Cairncross and Feachem (1993) Permission

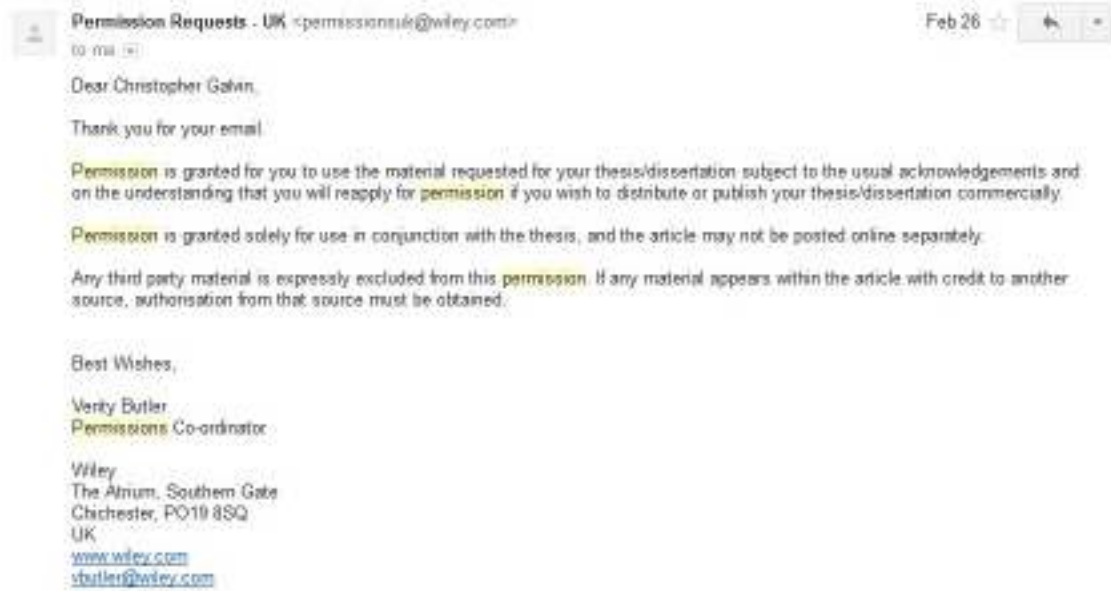

C.2 Buckley et al. (2008) Permission



C.3 Mihelcic et al. (2009) Permission

